

T 8390 EN

Type 3738-20 Electronic Limit Switch

With optional solenoid valve



Application

Electronic limit switch for on/off applications to indicate the end position. Optionally with integrated solenoid valve.

Special features

- Automation of on/off valves
- Limit switch and optional integrated solenoid valve united in a compact housing or with commercially available external solenoid valves (Ex ia, Ex e)
- Proven operating scheme already used in Series 373x Positioners: menu-driven, on-site operation using one rotary pushbutton, display easy to read in any mounting position
- Trouble-free integration into existing systems
 - NAMUR contacts (DIN EN 60947-5-6)
 - Solenoid valve 24 V DC
 - Intrinsically safe version
- Attachment
 - Rotary actuators according to VDI/VDE 3845
 - Linear actuators with NAMUR rib according to IEC 60534-6
- Compact mounting and simple operation
- Non-contact, wear-free travel sensor
 - Magnetoresistive sensor
 - No adjustment work necessary
 - Stable measured data and drift-free switching points
 - High level of accuracy
- Electronic limit switch powered over a two-wire system solely by the NAMUR signal
- Automatic initialization
- Easy-to-read LC display with selectable reading direction, LED for solenoid valve status
- Communication interface for convenient configuration and documentation
- Diagnostic functions
 - Partial stroke test (PST)
 - Movement counter
 - Operating hours counter
 - Dead time and transit time measurement



Fig. 1: Type 3738 Limit Switch with opened cover



Fig. 2: Type 3738 mounted on a piston actuator



Fig. 3: Type 3738 mounted on a linear actuator

Versions

- **Type 3738-20-xxx14xxxxx2xx Electronic Limit Switch with integrated solenoid valve**
 The electronic limit switch with integrated solenoid valve form a compact unit together with a pneumatic actuator, which is easy to mount. The 3/2-way or 5/2-way function of the solenoid valve is selected by changing the position of a molded seal.
- **Type 3738-20-xxx1000xxx200 Electronic Limit Switch with external solenoid valve**
 The electronic limit switch for an external solenoid valve allows switching capacities up to max. 18 W at 24 V DC, meaning all common solenoid valves, even the Ex e versions, can be combined with the electronic limit switch.

Principle of operation

The electronic limit switch is designed for attachment to pneumatic actuators. The angle of rotation is measured without contact using a magnet (on a screw) positioned centrally on the actuator shaft. The screw with magnet does not need to be adjusted. The AMR (anisotropic magnetoresistive) sensor located in the device together with the measuring electronics (1) can detect the directional change of the applied magnetic field and, as a result, sense the rotation of the actuator.

The actuator is operated by a solenoid valve (7) which converts the binary signal issued by the electric control equipment (6) into a binary pressure signal.

The limit switch for fail-safe position (contact A, 13) and the limit switch for operating position (contact B, 14) issue a limit signal when the valve reaches the corresponding end position. Contact C (15) indicates when the PST target range of the partial stroke test has been reached. The switching response of the contacts can be adjusted within the travel range. The fault alarm contact St (16) indicates the generation of any status and error messages.

An electronic limit switch version for an external solenoid valve is available for higher air capacities required by large actuators.

Schematic diagrams

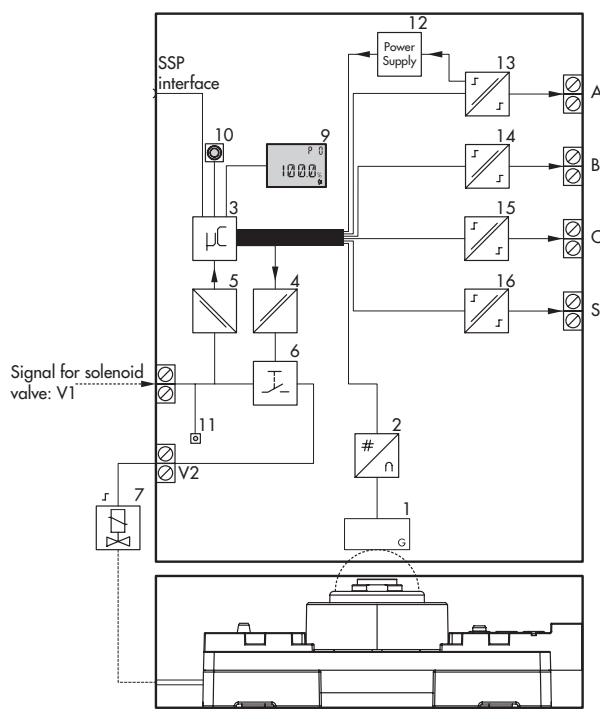
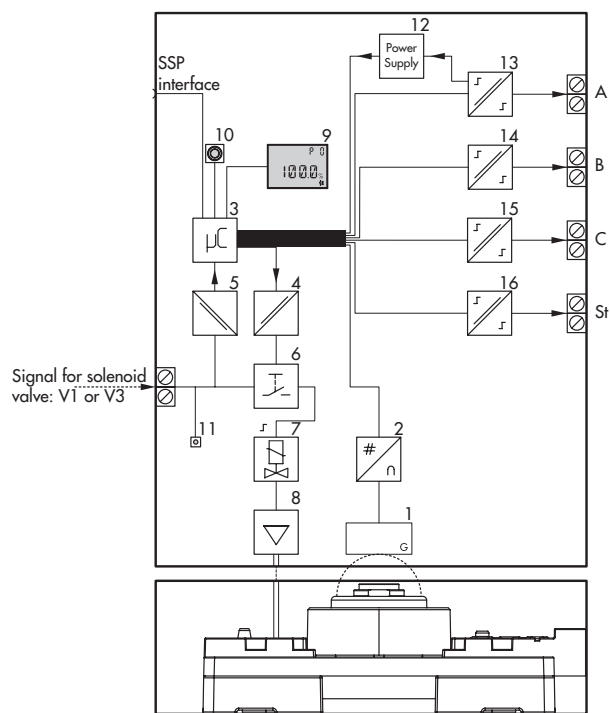

- | | | |
|-------------------------------|--|---|
| 1 AMR sensor with electronics | 7 Solenoid valve (integrated, external) | 12 Internal supply |
| 2 A/D converter | 8 Air capacity booster | 13 NAMUR contact A (limit switch for fail-safe position) |
| 3 Microcontroller | 9 Display | 14 NAMUR contact B (limit switch for operating position) |
| 4, 5 Electrical insulation | 10 Rotary pushbutton (on-site operation) | 15 NAMUR contact C (signal when PST target range reached) |
| 6 Actuation of solenoid valve | 11 LED for solenoid valve | 16 NAMUR contact St (fault alarm contact) |

Fig. 4: Type 3738-20-xxx14xxxxx2xx
 Version with integrated solenoid valve

Fig. 5: Type 3738-20-xxx1000xxx200
 Version with external solenoid valve

Operation

A rotary pushbutton and LC display are used to operate the electronic limit switch on site.

The functions for start-up, display readings and service functions are set over Codes (P0 to P28). When a fault occurs, a corresponding error code is displayed.

SAMSON's TROVIS-VIEW can be used to operate the electronic limit switch. An SSP interface on the electronic limit switch allows it to be connected to a computer using an adapter cable.

Attachment

- The electronic limit switch is mounted according to **VDI/VDE 3845**, fixing level 1 (2010) on rotary actuators using a mounting platform. Various mounting parts (accessories) are available depending on the follower shaft height of the rotary actuator. It is also possible to mount it onto a **PFEIFFER Type 31a Actuator (Edition 2020+)**. In this case, a hook-up is not necessary.
- Mounting kits for 15 to 120 mm rated travels are available for linear actuators with **NAMUR rib according to IEC 60534-6**. A solenoid valve with VDI/VDE 3847-1 interface can be fastened directly to electronic limit switches without integrated solenoid valve.

Pneumatic connections

Run and attach the connecting lines and screw joints according to good professional practice. Check them for leakage and damage at regular intervals and repair them, if necessary. Before starting any repair work, depressurize any open connecting lines.

The air connections are designed as threaded holes with G ¼ or ¼ NPT thread depending on the device version. Protect the exhaust air connections or vent plugs by installing a filter or taking other appropriate precautions to prevent water or dirt from entering them.

Operation using a pressure reducing valve: The K_{VS} coefficient of an upstream pressure reducing valve must be at least 1.6 times larger than the K_{VS} coefficient of the device.

Air pipe: The minimum nominal size of the air pipe must be a pipe with an inside diameter of ≥ 4 mm. A larger nominal size is needed when the connection length exceeds 2 m.

Operation with external solenoid valve: The input pressure at the external solenoid valve must not exceed the maximum supply pressure (refer to the specifications given by the solenoid valve manufacturer).

Electrical connections

The electronic limit switch is powered over the connection of the contact A. An additional electrical power supply is not required.

Cable entry

The threaded connection for the terminal compartment is designed with an M20x1.5 thread.

The screw terminals are designed for wire cross-sections of 0.2 to 1.5 mm². Tighten by at least 0.5 Nm.

Table 1: Technical data of the electronic limit switch

Electronic Limit Switch Type		3738-20-xxx14xxxxx2xx	3738-20-xxx1000xxx200	
Implementation		With integrated solenoid valve	For external solenoid valve	
Range of rotation	Minimum	0 to 30°		
	Maximum	0 to 170°		
Communication	Local communication	SAMSON SSP interface with serial interface adapter		
	Software requirements	TROVIS-VIEW with database module 3738-20		
Supply air		2.4 to 8 bar	Same as specifications of the solenoid valve manufacturer	
Air quality		Acc. to ISO 8573-1, edition 2004 Max. particle size and density: Class 4 Oil content: Class 3 Moisture and water: Class 3 · Pressure dew point at least 10 K below the lowest ambient temperature to be expected		
Air consumption		In idle position <60 l/h · In switching position <30 l/h		
Electric power supply		Powered over contact A according to DIN EN 60947-5-6		
Permissible ambient temperature The temperature limits for the explosion-protected devices may be restricted by the limits specified in the test certificates.		-25 to 80 °C	-40 to 80 °C Metal cable glands must be used for ambient temperatures below -20 °C. The limits specified in the examination certificate additionally apply.	
Influences	Temperature	±0.7 %/90° angle above the permissible temperature range		
	Effect of vibration	≤ 0.25 % up to 2500 Hz and 4 g according to IEC 770		
Electromagnetic compatibility		Complying with EN 61000-6-2, EN 61000-6-3, EN 61326-1 and NAMUR Recommendation NE 21		
Electrical connections		Four M20x1.5 cable glands for 6 to 12 mm clamping range, screw terminals for 0.2 to 2.5 mm ² wire cross-sections		
Explosion protection		See certificates in Table 3		
Degree of protection		IP 66		
Materials	Housing	Die-cast aluminum EN AC-ALSi12(Fe) (EN AC-44300) acc. to DIN EN 1706, powder paint coated		
	Housing cover	Computer		
	Cover gasket	PU		
	Indicator wheel	Computer		
	Magnet material	Hard ferrite		
Weight		Approx. 1.2 kg	Approx. 1.0 kg	
Contacts · Only for connection according to DIN EN 60947-5-6, reverse polarity protection, galvanic isolation				
Switching contacts		NC contact	NO contact	
No response/no fault		≥2.2 mA	≤1.0 mA	
Response/fault alarm		≤1.0 mA	≥2.2 mA	
Hysteresis		1 %		
Contacts	Contact A Limit contact for fail-safe position (solenoid valve de-energized)	PTO (power to open): responds when the valve moves through the switching contact towards the lower end position PTC (power to close): responds when the valve moves through the switching contact towards the upper end position		
	Contact B Limit contact for operating position (solenoid valve energized)	PTO (power to open): responds when the valve moves through the switching contact towards the upper end position PTC (power to close): responds when the valve moves through the switching contact towards the lower end position		
		Signal for wire breakage according to DIN EN 60947-5-6		





Electronic Limit Switch Type		3738-20-xxx14xxxxx2xx	3738-20-xxx1000xxx200
Version		With integrated solenoid valve	For external solenoid valve
Contacts	Contact C Signal when target range reached during partial stroke test Limit contact for intermediate position	Responds when the valve reaches the PST target range (= PST step final value \pm 1/2 PST tolerance band) PTO (power to open): Responds when the valve moves through the switching contact towards the operating position PTC (power to close): Responds when the valve moves through the switching contact towards the fail-safe position	
	Contact St Fault alarm contact	Responds when a status message or error message is generated Switching function of NC contact cannot be changed	
Current specifications when contact A is not connected		Contact B: I = 50 μ A (wire breakage) Contact C: I = 1.2 mA Contact St: I = 1.2 mA	
Compliance			

Table 2: Technical data of solenoid valve

Integrated solenoid valve (Type 3738-20-xxx14xxxxx2xx)		
Version	3/2-way or 5/2-way function Function determined by the position of the molded seal	
K_{VS} coefficient	0.32	
Service life	1,000,000 switching cycles	
Temperature range (operation)	-25 to +80 °C	
Switching voltage	Nominal voltage	24 V DC, reverse polarity protection, galvanic isolation
	Current draw	$I = 2.7 \times U / (3650 \Omega) - 3.325 \text{ mA}$ · Corresponding to 14.4 mA at 24 V DC
	Signal 0	When the voltage falls below 15 V DC
	Signal 1	Min. 18 V DC
Switching capacity	24 V DC; 15.2 mA (0.36 W)	
Duty cycle	100 %	
Static destruction limit	32 V DC	
External solenoid valve (for Type 3730-20-xxx1000xxx200)		
Read manufacturer's specifications!		
Nominal voltage	24 V DC, max. 18 W	
Switching voltage	Signal 0	When the voltage falls below 15 V DC
	Signal 1	Min. 18 V DC
Static destruction limit	32 V DC	

Table 3: Summary of explosion protection certificates for Type 3738-20 Electronic Limit Switch

Type	Certification	Type of protection/comments		
3738-20	-110  EC type examination certificate	Number	PTB 08 ATEX 2039 X	II 2G Ex ia IIC T6; II 2D Ex ia IIIC T80°C IP66
		Date	2012-07-19	
	-310  EC type examination certificate	Number	PTB 08 ATEX 2039 X	II 2G Ex eb[ia] IIC T4; II 2D Ex tb IIIC T80°C IP66
	Date	2012-07-19		
-810  EC type examination certificate	Number	PTB 08 ATEX 2039 X	II 3G Ex ic IIC T4; II 3G Ex nA II T4 Gc; II 3D Ex tc IIIC T80°C IP66	
	Date	2012-07-19		

Electrical connections

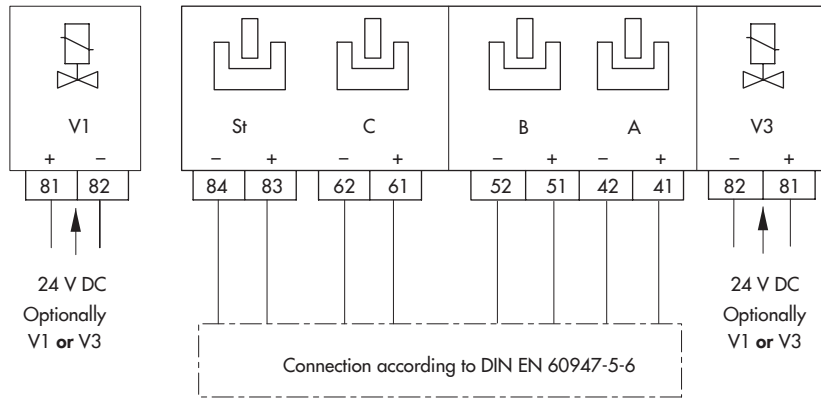

Fig. 6: Version with integrated solenoid valve (Type 3738-20-xxx14xxxxx2xx)

NOTICE
Only connect one pair of 81/82 terminals.

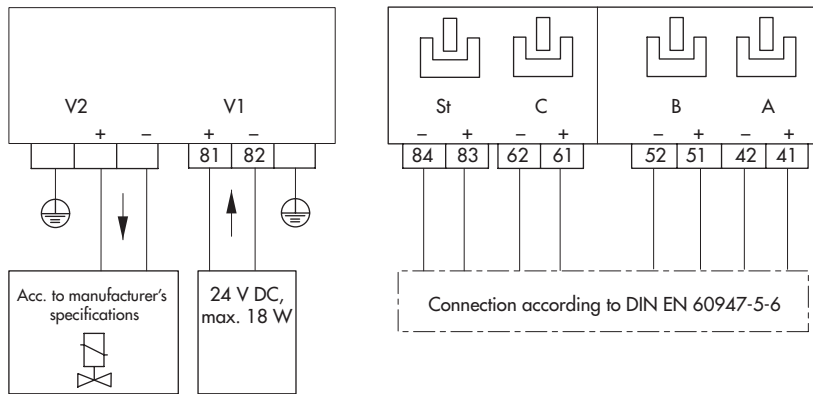
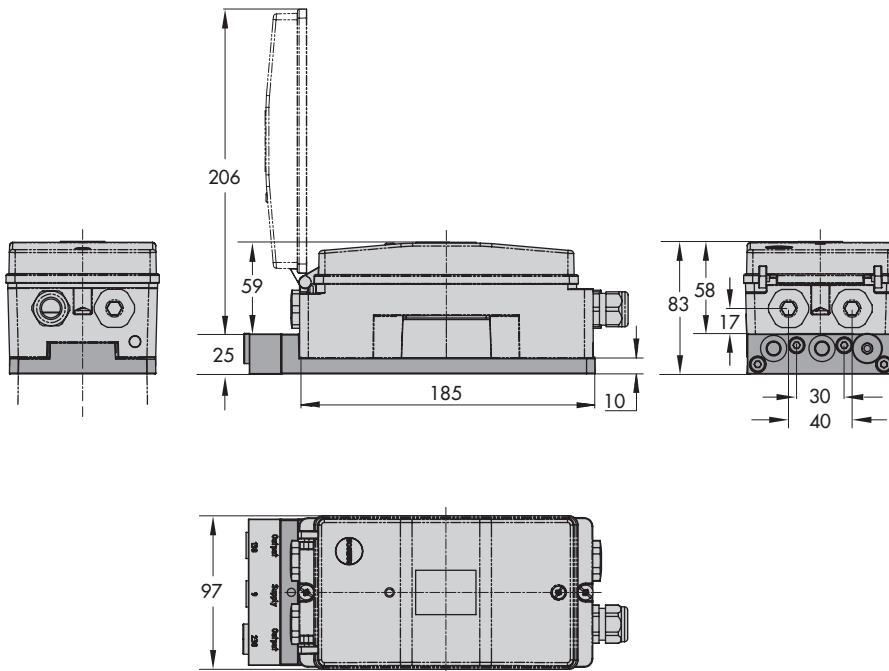
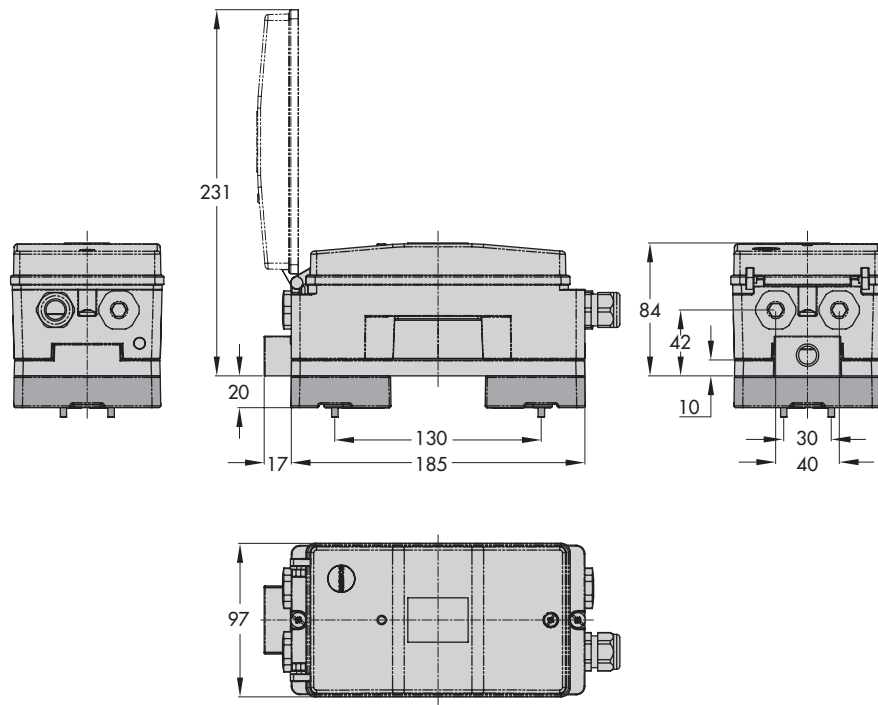

Fig. 7: Version with external solenoid valve (Type 3738-20-xxx1000xxx200)

Dimensions in mm (all pneumatic connections in G 1/4 or 1/4 NPT)



Dimensions for mounting onto rotary actuators according to VDI/VDE 3845 using a mounting platform



Mounting onto PFEIFFER Type 31a Actuator (Edition 2020+)

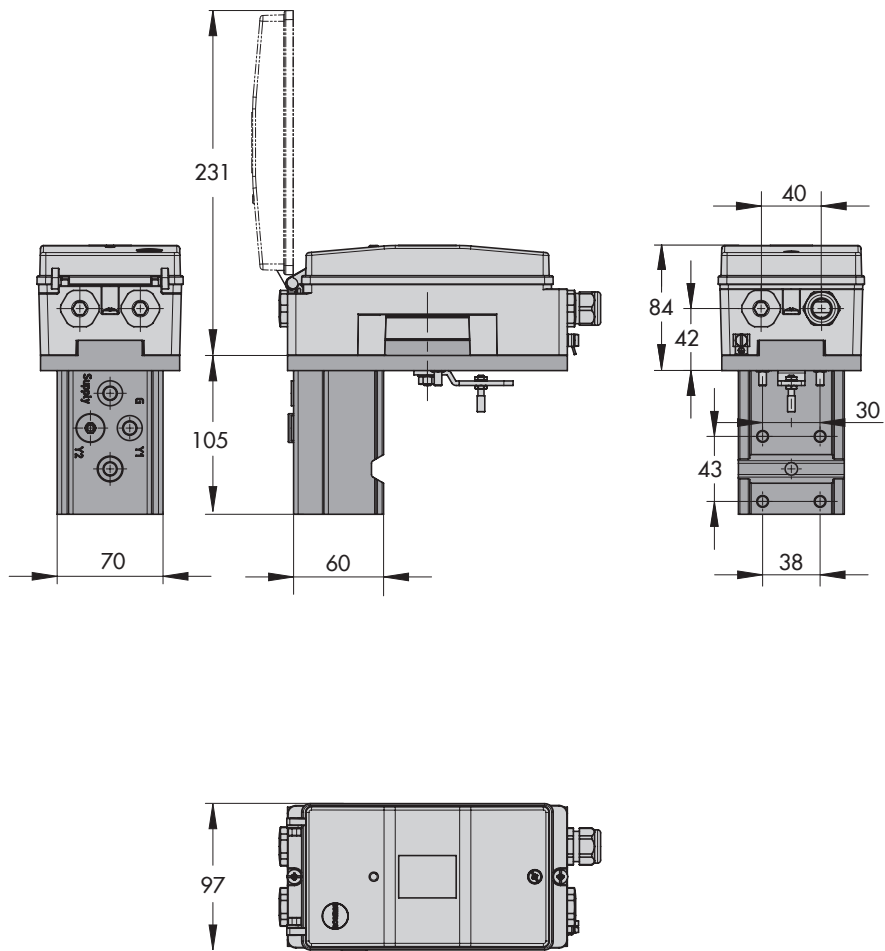

Mounting onto linear actuators according to IEC 60534-6 (NAMUR)

Article code

Type 3738-20 Electronic Limit Switch	x	x	x	1	x	0	0	x	x	x	2	0	x
With LCD													
Explosion protection													
Without	0	0	0										
ATEX: II 2G Ex ia IIC T ₆ ; II 2D Ex ia IIIC T ₈₀ °C IP66	1	1	0										
ATEX: II 2G Ex eb[ia] IIC T ₄ ; II 2D Ex tb IIIC T ₈₀ °C IP66	3	1	0	0									
ATEX: II 3G Ex ic IIC T ₄ ; II 3G Ex nA II T ₄ Gc; II 3D Ex tc IIIC T ₈₀ °C IP66	8	1	0										
Solenoid valve													
External				0									
Integrated				4									
Company version													
SAMSON								0					
AIR TORQUE ¹⁾								1					
Housing													
Standard aluminum, black structured, RAL 9005									1				
Cover													
Gray beige										0			
Black ¹⁾										1			
Silver gray ¹⁾										3			
Special applications													
Without													0

¹⁾ No longer available after January 2018

Ordering text

Electronic limit switch	Type 3738-20
Explosion protection	With/without
Solenoid valve	Integrated/external
Company version	SAMSON/AIR TORQUE
Housing cover version	See article code
Safety approval	With/without
Special applications	
Mounting accessories	
TROVIS-VIEW	

Associated Information Sheet

► T 8350