

# MOUNTING AND OPERATING INSTRUCTIONS

The SAMSON logo consists of the word "SAMSON" in a bold, white, sans-serif font, centered within a solid black circle. This circle is itself centered within a white square frame.

## EB 9910 EN

Translation of original instructions

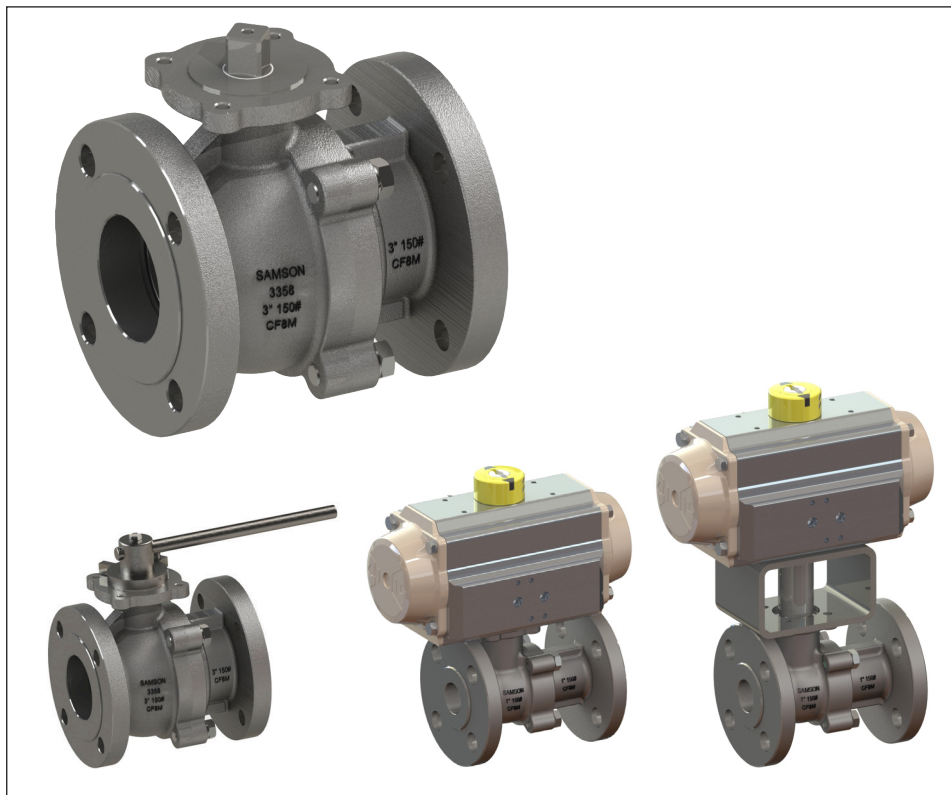

### Type 3358 Ball Valve · ANSI version

For combination with a lever or  
a pneumatic or electric part-turn actuator

Edition October 2024

---

## Note on these mounting and operating instructions

These mounting and operating instructions assist you in mounting and operating the device safely. The instructions are binding for handling SAMSON devices. The images shown in these instructions are for illustration purposes only. The actual product may vary.

- For the safe and proper use of these instructions, read them carefully and keep them for later reference.
- If you have any questions about these instructions, contact SAMSON's After-sales Service (info@samsoncontrols.net).



Documents relating to the device, such as the mounting and operating instructions, are available on our website at [www.samsongroup.com](http://www.samsongroup.com) > **Downloads > Documentation.**

## Definition of signal words

### **DANGER**

*Hazardous situations which, if not avoided, will result in death or serious injury*

### **WARNING**

*Hazardous situations which, if not avoided, could result in death or serious injury*

### **NOTICE**

*Property damage message or malfunction*

### **Note**

*Additional information*

### **Tip**

*Recommended action*

<b>1</b>	<b>Safety instructions and measures</b> .....	<b>1-1</b>
1.1	Notes on possible severe personal injury .....	1-4
1.2	Notes on possible personal injury .....	1-4
1.3	Notes on possible property damage .....	1-6
<b>2</b>	<b>Markings on the device</b> .....	<b>2-1</b>
2.1	Ball valve nameplate .....	2-1
2.2	Actuator nameplate .....	2-1
<b>3</b>	<b>Design and principle of operation</b> .....	<b>3-1</b>
3.1	Fail-safe action .....	3-1
3.2	Versions .....	3-1
3.3	Valve accessories .....	3-1
3.4	Technical data .....	3-4
<b>4</b>	<b>Shipment and on-site transport</b> .....	<b>4-1</b>
4.1	Accepting the delivered goods .....	4-1
4.2	Removing the packaging from the ball valve .....	4-1
4.3	Transporting and lifting the ball valve .....	4-1
4.3.1	Transporting the ball valve .....	4-2
4.3.2	Lifting the ball valve .....	4-3
4.4	Storing the ball valve .....	4-4
<b>5</b>	<b>Installation</b> .....	<b>5-1</b>
5.1	Installation conditions .....	5-1
5.2	Preparation for installation .....	5-2
5.3	Mounting the device .....	5-3
5.3.1	Mounting the actuator onto the ball valve .....	5-3
5.3.2	Installing the ball valve into the pipeline .....	5-3
5.3.3	Connecting the supply air or electrical power to a mounted actuator .....	5-4
5.4	Testing the installed ball valve .....	5-4
5.4.1	Leakage .....	5-5
5.4.2	Rotary motion .....	5-5
5.4.3	Fail-safe position .....	5-5
5.4.4	Pressure test .....	5-6
<b>6</b>	<b>Start-up</b> .....	<b>6-1</b>
<b>7</b>	<b>Operation</b> .....	<b>7-1</b>
7.1	Operation with a part-turn actuator .....	7-2
7.2	Manual operation .....	7-2

## Contents

<b>8</b>	<b>Malfunctions</b> .....	<b>8-1</b>
8.1	Troubleshooting .....	8-1
8.2	Emergency action .....	8-2
<b>9</b>	<b>Servicing</b> .....	<b>9-1</b>
9.1	Periodic testing .....	9-2
<b>10</b>	<b>Decommissioning</b> .....	<b>10-1</b>
<b>11</b>	<b>Removal</b> .....	<b>11-1</b>
11.1	Removing the ball valve from the pipeline .....	11-2
11.2	Removing the actuator from the valve .....	11-2
<b>12</b>	<b>Repairs</b> .....	<b>12-1</b>
12.1	Returning devices to SAMSON .....	12-1
<b>13</b>	<b>Disposal</b> .....	<b>13-1</b>
<b>14</b>	<b>Certificates</b> .....	<b>14-1</b>
<b>15</b>	<b>Appendix</b> .....	<b>15-1</b>
15.1	Tightening torques, lubricants and tools .....	15-1
15.2	After-sales service .....	15-2

# 1 Safety instructions and measures

## Intended use

The Type 3358 Ball Valve is used in combination with a lever or, alternatively, an electric or pneumatic part-turn actuator for on/off applications in various industrial sectors. The valve assembly is suitable for liquids, vapors and gases.

The ball valve with its actuator is designed to operate under exactly defined conditions (e.g. operating pressure, process medium, temperature). Therefore, operators must ensure that the valve assembly is only used in operating conditions that meet the specifications used for sizing the valve assembly at the ordering stage. In case operators intend to use the valve assembly in applications or conditions other than those specified, contact SAMSON.

SAMSON does not assume any liability for damage resulting from the failure to use the device for its intended purpose or for damage caused by external forces or any other external factors.

→ Refer to the technical data and nameplate for limits and fields of application as well as possible uses.

## Reasonably foreseeable misuse

The valve assembly is not suitable for the following applications:

- Use outside the limits defined during sizing and by the technical data
- Use outside the limits defined by the accessories connected to the valve assembly

Furthermore, the following activities do not comply with the intended use:

- Use of non-original spare parts
- Performing service and repair work not described

## Qualifications of operating personnel

The device must be mounted, started up, serviced and repaired by fully trained and qualified personnel only; the accepted industry codes and practices must be observed. According to these mounting and operating instructions, trained personnel refers to individuals who are able to judge the work they are assigned to and recognize possible hazards due to their specialized training, their knowledge and experience as well as their knowledge of the applicable standards.

## Safety instructions and measures

### Personal protective equipment

SAMSON recommends checking the hazards posed by the process medium being used (e.g. ► GESTIS (CLP) hazardous substances database). Depending on the process medium and/or the activity, the protective equipment required includes:

- Protective clothing, gloves, eye protection and respiratory protection in applications with hot, cold and/or corrosive media
  - Hearing protection when working near the ball valve
  - Hard hat
  - Safety harness, e.g. when working at height
  - Safety footwear, if applicable ESD (electrostatic discharge) footwear
- ➔ Check with the plant operator for details on further protective equipment.

### Revisions and other modifications

Revisions, conversions or other modifications of the product are not authorized by SAMSON. They are performed at the user's own risk and may lead to safety hazards, for example. Furthermore, the product may no longer meet the requirements for its intended use.

### Safety features

The fail-safe position of the valve assembly upon air supply or control signal failure depends on the actuator used (see associated actuator documentation). When the ball valve is combined with a lever, the valve assembly does not automatically move to a fail-safe position.

### Warning against residual hazards

To avoid personal injury or property damage, plant operators and operating personnel must prevent hazards that could be caused in the valve assembly by the process medium, the operating pressure, the signal pressure or by moving parts by taking appropriate precautions. Plant operators and operating personnel must observe all hazard statements, warnings and caution notes in these mounting and operating instructions.

It is the plant operator's responsibility to take appropriate precautions to prevent pressure surges in the pipeline. Pressure surges can damage the ball valve. In extreme cases, the ball valve can burst and lead to personal injury. In cases in which pressure surges cannot be adequately avoided, the plant operator must size the pipeline to withstand additional loads.

Hazards resulting from the special working conditions at the installation site of the ball valve must be identified in a risk assessment and prevented through the corresponding safety instructions drawn up by the operator.

### **Responsibilities of the operator**

Operators are responsible for proper use and compliance with the safety regulations. Operators are obliged to provide these mounting and operating instructions as well as the referenced documents to the operating personnel and to instruct them in proper operation. Furthermore, operators must ensure that operating personnel or third parties are not exposed to any danger.

Operators are additionally responsible for ensuring that the limits for the product defined in the technical data are observed. This also applies to the start-up and shutdown procedures. Start-up and shutdown procedures fall within the scope of the operator's duties and, as such, are not part of these mounting and operating instructions. SAMSON is unable to make any statements about these procedures since the operative details (e.g. differential pressures and temperatures) vary in each individual case and are only known to the operator.

### **Responsibilities of operating personnel**

Operating personnel must read and understand these mounting and operating instructions as well as the referenced documents and observe the specified hazard statements, warnings and caution notes. Furthermore, operating personnel must be familiar with the applicable health, safety and accident prevention regulations and comply with them.

### **Referenced standards, directives and regulations**

The ball valves meet the requirements of the Indian Boiler Regulations (IBR).

### **Referenced documents**

The following documents apply in addition to these mounting and operating instructions:

- Mounting and operating instructions for the mounted actuator
- Mounting and operating instructions for mounted valve accessories (positioner, solenoid valve etc.)

## 1.1 Notes on possible severe personal injury

### DANGER

#### **Risk of bursting in pressure equipment.**

Ball valve assemblies and pipelines are pressure equipment. Excessive pressurization or improper opening can lead to valve components bursting.

- Observe the maximum permissible pressure for ball valve and plant.
- Before starting any work on the valve assembly, depressurize all plant sections affected as well as the ball valve.
- Drain the process medium from the plant sections affected as well as from the ball valve.

#### **Risk of pipes bursting.**

A ball valve that is suddenly opened or closed can cause pressure surges and/or temperature shocks in the pipeline.

- Apply an even and steady pressure to the lever to open and close the ball valve.

## 1.2 Notes on possible personal injury

### WARNING

#### **Risk of burn injuries due to hot or cold components and pipelines.**

Depending on the process medium, components of the ball valve as well as the pipelines may get very hot or cold and cause burn injuries.

- Allow components and pipelines to cool down or warm up to the ambient temperature.
- Wear protective clothing and safety gloves.

#### **Risk of hearing loss or deafness due to loud noise.**

The noise emissions depend on the ball valve version, plant facilities and process medium.

- Wear hearing protection when working near the ball valve



**⚠ WARNING**

**Risk of personal injury due to exhaust air being vented from pneumatically operated components.**

When the ball valve is operated with a pneumatic actuator or pneumatic valve accessories, exhaust air may be vented from the actuator, for example, while the ball valve is operating in closed-loop control or when the ball valve opens or closes.

- Install the valve assembly in such a way that vent openings are not located at eye level and the actuator does not vent at eye level in the work position.
- Use suitable silencers and vent plugs.
- Wear eye protection when working in close proximity to the valve.

**Crush hazard arising from moving parts.**

The ball rotates inside the valve body. Crush injuries to hands or fingers may occur if they are inserted into the valve.

- Do not insert hands or fingers into the ball valve body.
- Before working on the valve assembly, release any energy (in the actuator) which causes the shaft to move (e.g. also the spring compression).
- Before working on the valve assembly, disconnect and lock the pneumatic air supply as well as the control signal.
- Disconnect the supply voltage before performing any work on the valve assembly.
- Do not impede the rotary motion of the ball by inserting objects into its path.
- Before attempting to unblock a ball after it has become blocked (e.g. due to seizing up after remaining in the same position for a long time), release any energy (in the actuator) which causes the valve shaft to move.

**Risk of personal injury due to preloaded springs.**

Valves in combination with pneumatic actuators with preloaded springs are under tension.

- Before starting any work on the actuator, relieve the compression from the preloaded springs (see associated actuator documentation).

### WARNING

#### **Risk of personal injury due to residual process medium in the ball valve.**

While working on the ball valve, residual medium can flow out of the valve and, depending on its properties, cause personal injury, e.g. (chemical) burns.

- If possible, drain the process medium from the plant sections affected and from the ball valve.
- Wear protective clothing, safety gloves, respiratory protection and eye protection.

#### **Risk of personal injury due to incorrect operation, use or installation as a result of information on the valve assembly being illegible.**

Over time, markings, labels and nameplates on the valve assembly may become covered with dirt or become illegible in some other way. As a result, hazards may go unnoticed and the necessary instructions not followed. There is a risk of personal injury.

- Keep all relevant markings and inscriptions on the device in a constantly legible state.
- Immediately renew damaged, missing or incorrect nameplates or labels.

## 1.3 Notes on possible property damage

### NOTICE

#### **Risk of malfunction of the ball valve due to the vibrations caused by the plant.**

- If severe plant vibrations are likely to occur, use a locking facility to lock the position of a manually operated ball valve to prevent it from inadvertently opening or closing.

#### **Risk of malfunction or damage to the ball valve due to incorrectly sized electric or pneumatic actuator.**

The torques and initial breakaway torques required to operate the ball valve vary depending on the opening and closing state of the valve. The materials for the ball and shaft additionally determine the maximum permissible torque.

- The required torques and the maximum permissible torques specified in Data Sheet  T 9910 must be taken into account on sizing the actuator.

**! NOTICE**

**Risk of damage to the ball valve due to contamination (e.g. solid particles) in the pipeline.**

The plant operator is responsible for cleaning the pipelines in the plant.

→ Flush the pipelines before start-up.

**Risk of damage to the ball valve due to unsuitable medium properties.**

The ball valve is designed for a process medium with defined properties.

→ Only use the process medium specified for sizing the equipment.

**Risk of leakage and ball valve damage due to over- or under-torquing.**

Observe the specified torques when tightening valve components. Excessive tightening torques lead to parts wearing out more quickly. Parts that are too loose may cause leakage.

→ Observe the specified tightening torques.

**Risk of damage to the ball valve due to the use of unsuitable tools.**

Certain tools are required to work on the ball valve.

→ Only use tools approved by SAMSON.

**Risk of damage to the ball valve due to the use of unsuitable lubricants.**

The lubricants to be used depend on the ball valve material. Unsuitable lubricants may corrode and damage surfaces.

→ Only use lubricants approved by SAMSON.

**Risk of the process medium being contaminated through the use of unsuitable lubricants and/or contaminated tools and components.**

→ If necessary, keep the ball valve and the tools used free from solvents and grease.

→ Make sure that only suitable lubricants are used.



## 2 Markings on the device

The nameplate shown was up to date at the time of publication of this document. The nameplate on the device may differ from the one shown.

### 2.1 Ball valve nameplate

The valve nameplate is located on the ball valve body.

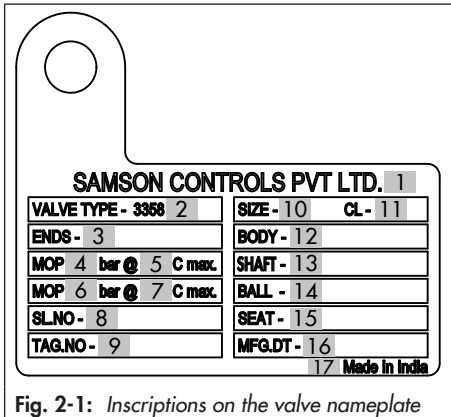

Fig. 2-1: Inscriptions on the valve nameplate

Item	Inscription meaning
1	Manufacturer
2	Model number
3	Type of end connections
4	Maximum operating pressure 1
5	Temperature in °C at specified pressure 1
6	Maximum operating pressure 2
7	Temperature in °C at specified pressure 2
8	Serial number
9	Tag number
10	Nominal size
11	Pressure rating

Item	Inscription meaning
12	Body material
13	Shaft material
14	Ball material
15	Seat material
16	Date of manufacture
17	Country of origin

### 2.2 Actuator nameplate

See associated actuator documentation.



### 3 Design and principle of operation

See Fig. 3-1 to Fig. 3-4

The Type 3358 Ball Valve is suitable for both directions of flow with an unobstructed, straight-through flow path (full bore).

The ball (3) rotates around a shaft (5) and has a cylindrical passage. The opening angle of the ball (3) determines the flow rate across the free area between the body (1 and 2) and the ball channel. The seat of the ball (3) is sealed by exchangeable seat rings (4).

The shaft (5) of the **standard version** is sealed by O-rings (6).

The shaft (5) of the **fire-safe version** is sealed by a graphite packing (11 to 16).

The open end of the shaft (5) is fitted with a lever. Optionally, a pneumatic or electric part-turn actuator can be mounted on the valve.

#### 3.1 Fail-safe action

The fail-safe position of the valve upon air supply or control signal failure depends on the actuator used (see associated actuator documentation).

The valve fitted with a corresponding pneumatic or electric actuator can assume one of two fail-safe positions that become effective after the supply air or electrical power fails depending on the actuator version.

#### – Fail-close valve

The ball valve is closed by the force of the actuator springs upon failure of the air supply/electrical power.

#### – Fail-open valve

The ball valve is opened by the force of the actuator springs upon failure of the air supply/electrical power.

When the ball valve is combined with a lever, the valve assembly does not automatically move to a fail-safe position.

### 3.2 Versions

#### Shaft

- A shaft extension can be mounted on the ball valve.
- The ball valve can be fitted with a square drive shaft, which is offset by 45°.

#### Actuators

The Type 3358 Ball Valve can be combined with a lever or an electric or pneumatic part-turn actuator to form a ball valve assembly.

The required torques and the maximum permissible torques must be taken into account when sizing a pneumatic or electric actuator for the Type 3358 Ball Valve (see Data Sheet ► T 9910).

### 3.3 Valve accessories

Information Sheet ► T 8350

## Design and principle of operation

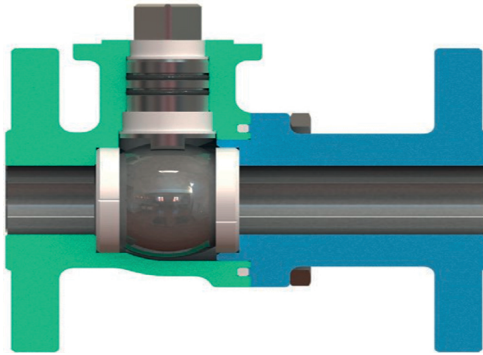

Fig. 3-1: Sectional view of the standard version

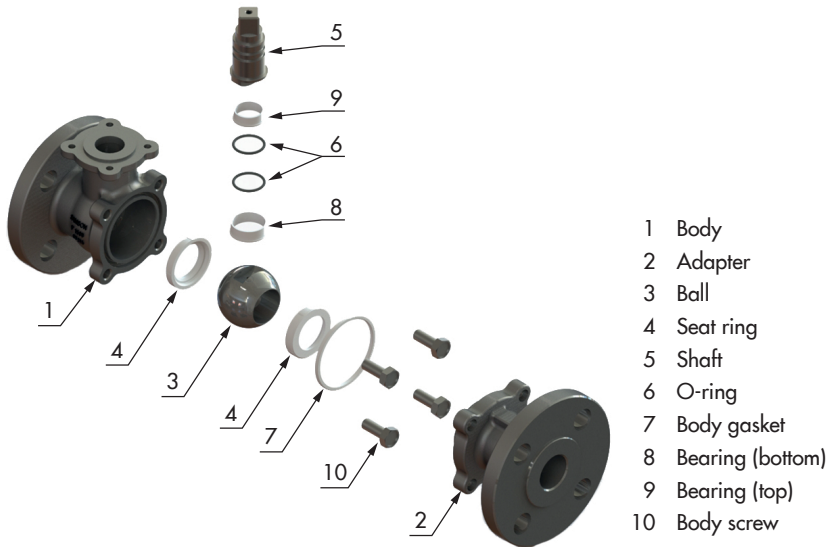

Fig. 3-2: Exploded diagram of the standard version



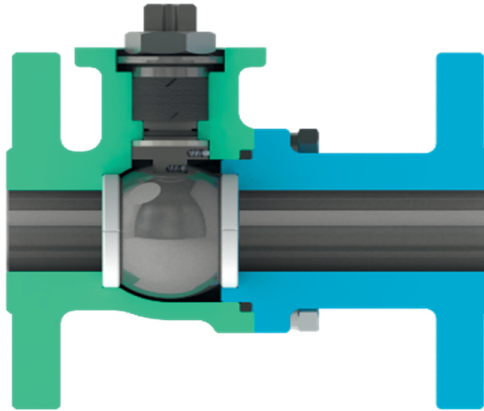

Fig. 3-3: Sectional view of the fire-safe version

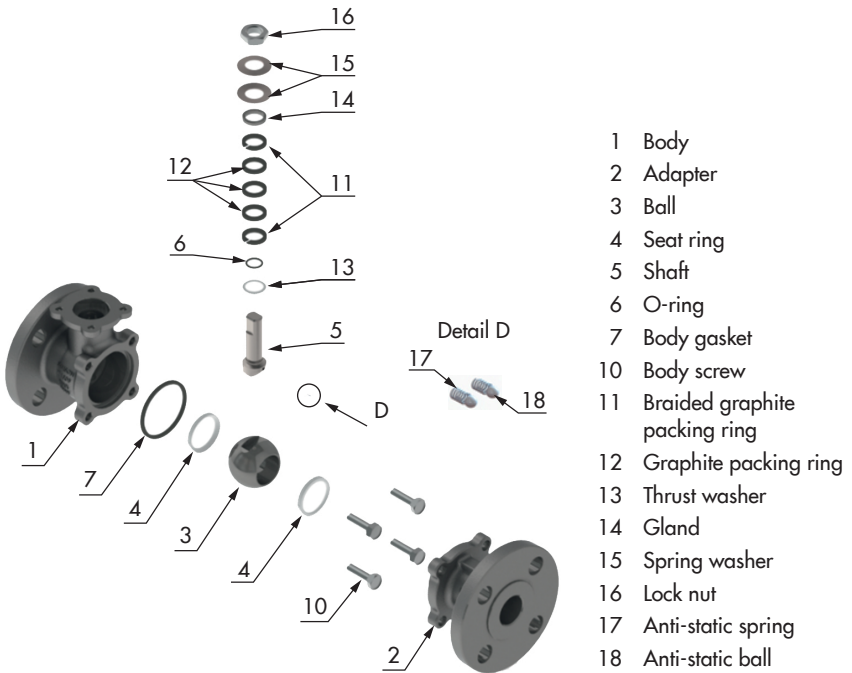

Fig. 3-4: Exploded diagram of the fire-safe version

### 3.4 Technical data

The nameplates on the ball valve and actuator provide information on the valve version. See the 'Markings on the device' chapter.

**i Note**

More information is available in Data Sheet T 9910.

#### Conformity

The Type 3358 Ball Valve complies with the requirements of IBR (Indian Boiler Regulations).

#### Noise emissions

SAMSON is unable to make general statements about noise emissions. The noise emissions depend on the ball valve version, plant facilities and process medium.

**Table 3-1:** Technical data of Type 3358 Ball Valve

Nominal size	NPS	1 to 6	
Material		Cast stainless steel A351 CF8M	Cast steel A216 WCC
Pressure rating		Class 150/300	
Type of end connections	Flanges	ASME B16.5	
Face-to-face dimension		ASME B16.10, API 6D	
Design and manufacturing		API 6D, BS EN ISO 17292	
Conformity		IBR (Indian Boiler Regulations)	
<b>Temperature range</b> · Permissible operating pressures in Data Sheet ▶ T 9910			
Standard version		-29 to +220 °C (-20 to 428 °F)	
<b>Leakage class</b>			
According to API 598/API 6D		Tight Shut Off	

**Table 3-2:** *Materials <sup>1)</sup> for standard version*

Body and adapter (1 and 2)	A351 CF8M	A216 WCC
Ball	A182 F316/F316L	
Seat rings	TFM 1600/RPTFE	
Shaft	A479 SS316/SS316L/A182 F51/A564 17-4PH	
Shaft seal (O-rings)	FKM	
Bearing	PTFE/CFT	
Body gasket	PTFE/graphite	

<sup>1)</sup> Other materials on request

**Table 3-3:** *Materials <sup>1)</sup> for fire-safe version*

Body and adapter (1 and 2)	A351 CF8M	A216 WCC
Ball	A182 F316/F316L	
Seat rings	RPTFE	
Shaft	A479 SS316/SS316L/A182 F51/A564 17-4PH	
Shaft seal (O-rings)	FKM	
Thrust washer	GFT	
Packing	Graphite	
Body gasket	Graphite	

<sup>1)</sup> Other materials on request

## Design and principle of operation

### Dimensions and weights

The weights specified apply to a specific standard device configuration. Weights of other valve configurations may differ depending on the version (material, trim etc.).

Dimensions (in inch and mm) and weights (in lbs and kg)

**Table 3-4:** Dimensions for Type 3358 Ball Valve without actuator (see Fig. 3-5 and Fig. 3-6)

Nominal size		NPS	1	1½	2	3	4	6
FTF	Class 150	in	5	6.5	7.01	7.99	9.02	15.51
		mm	127	165	178	203	229	394
	Class 300	in	6.5	7.48	8.5	11.14	12.01	15.87
		mm	165	190	216	283	305	403
ØD	Class 150	in	4.33	4.92	5.91	7.48	9.06	11.02
		mm	110	125	150	190	230	280
	Class 300	in	4.92	6.1	6.5	8.27	10	12.52
		mm	125	155	165	210	254	318
ØK	Class 150	in	3.13	3.88	4.75	6	7.5	9.5
		mm	79.4	98.6	120.6	152.4	190.5	241.3
	Class 300	in	3.5	4.5	5	6.62	7.88	10.62
		mm	88.9	114.3	127	168.1	200.2	269.7
N x Ø	Class 150	in	4x 0.63	4x 0.63	4x 0.75	4x 0.75	8x 0.75	8x 0.87
		mm	4x 16	4x 16	4x 19	4x 19	8x 19	8x 22.2
	Class 300	in	4x 0.75	4x 0.87	8x 0.75	8x 0.87	8x 0.87	12x 0.87
		mm	4x 19	4x 22.2	8x 19	8x 22.2	8x 22.2	12x 22.2
SQ (standard version)	Class 150	in	0.55	0.67	0.67	0.87	0.87	1.42
		mm	14	17	17	22	22	36
	Class 300	in	0.55	0.67	0.67	0.87	0.87	1.42
		mm	14	17	17	22	22	36
SQ (fire-safe version)	Class 150	in	0.55	0.67	0.67	0.87	1.06	1.42
		mm	14	17	17	22	27	36
	Class 300	in	0.55	0.67	0.67	0.87	1.06	1.42
		mm	14	17	17	22	27	36

Nominal size		NPS	1	1½	2	3	4	6
H	Class 150	in	2.56	3.01	3.33	5.06	6.63	8.35
		mm	65	76.5	84.5	128.5	168.5	212
	Class 300	in	2.22	2.62	2.95	4.59	6.12	7.72
		mm	56.5	66.5	75	116.5	155.5	196
E	in	0.57	0.71	0.71	0.98	0.98	1.14	
	mm	14.5	18	18	25	25	29	
G	in	0.65	0.78	0.78	0.98	1.2	1.57	
	mm	16.5	19.5	19.5	25	30.5	40	
F according to DIN EN ISO 5211			F05	F07	F07	F10	F10	F14

**Table 3-5:** *Weights for Type 3358 Ball Valve without actuator*

Nominal size		NPS	1	1½	2	3	4	6
Weight	Class 150	lbs	6.6	12.6	20.1	44.1	63.9	143.3
		kg	3	5.7	9.1	20	29	65
	Class 300	lbs	9.3	16.8	30.9	63.1	93.7	189.6
		kg	4.2	7.6	14	28.6	42.5	86

Dimensional drawing

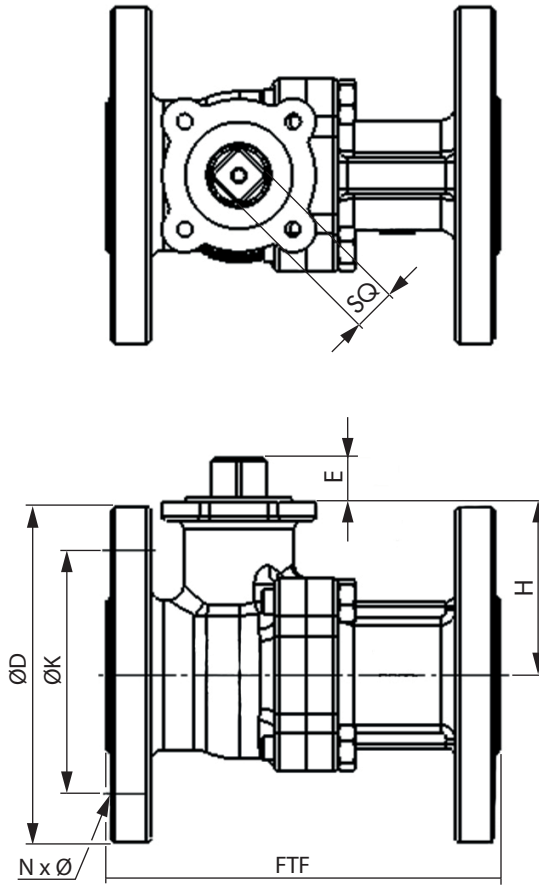

Fig. 3-5: Standard version

Dimensional drawing

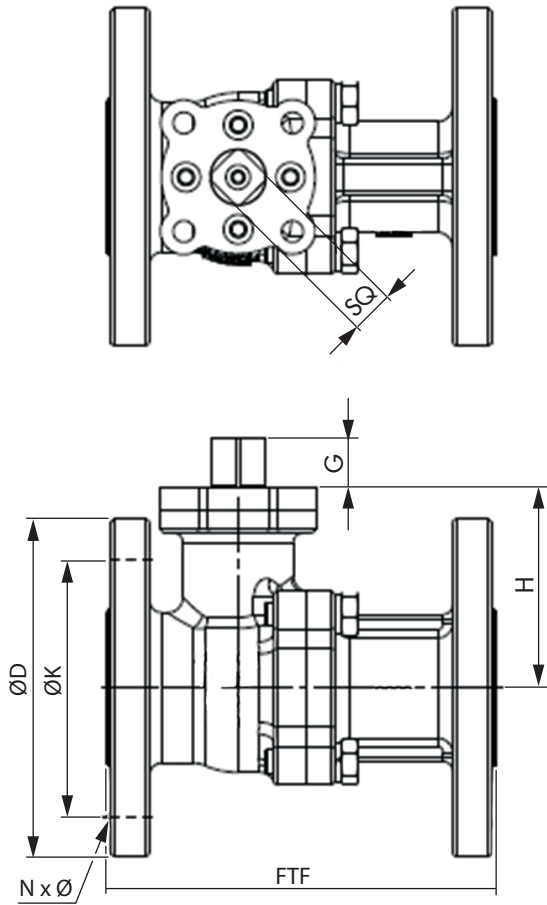

Fig. 3-6: Fire-safe version

**i** Note

The associated actuator documentation applies to actuators.





## 4 Shipment and on-site transport

The work described in this chapter is to be performed only by personnel appropriately qualified to carry out such tasks.

### 4.1 Accepting the delivered goods

After receiving the shipment, proceed as follows:

1. Check the scope of delivery. Check that the specifications on the ball valve nameplate match the specifications in the delivery note. See the 'Markings on the device' chapter for nameplate details.
2. Check the shipment for transportation damage. Report any damage to SAMSON and the forwarding agent (refer to delivery note).
3. Determine the weight and dimensions of the units to be lifted and transported in order to select the appropriate lifting equipment and lifting accessories, if required. Refer to the transport documents and the 'Technical data' chapter.

### 4.2 Removing the packaging from the ball valve

Observe the following sequence:

- Do not open or remove the packaging until immediately before lifting to install the valve assembly into the pipeline.

- Leave the valve assembly in its transport container or on the pallet to transport it on site.
- Do not remove the protective caps from the inlet and outlet until immediately before installing the ball valve into the pipeline. They prevent foreign particles from entering the ball valve.
- Dispose and recycle the packaging in accordance with the local regulations.

### 4.3 Transporting and lifting the ball valve

---

#### **⚠ DANGER**

***Danger due to suspended loads falling.***

- *Stay clear of suspended or moving loads.*
  - *Close off and secure the transport paths.*
- 

#### **⚠ WARNING**

***Risk of lifting equipment tipping over and risk of damage to lifting accessories due to exceeding the rated lifting capacity.***

- *Only use approved lifting equipment and accessories whose minimum lifting capacity is higher than the weight of the ball valve (including actuator and packaging, if applicable).*
-

### **⚠ WARNING**

**Risk of personal injury due to the valve assembly tipping.**

- Observe the center of gravity of the valve assembly.
- Secure the valve assembly against tipping over or turning.

### **⚠ WARNING**

**Risk of injury due to incorrect lifting without the use of lifting equipment.**

Lifting the valve assembly without the use of lifting equipment may lead to injuries (back injuries in particular) depending on its weight.

- Observe the occupational health and safety regulations valid in the country of use.

### **ⓘ NOTICE**

**Risk of damage to the valve assembly due to incorrectly attached slings.**

- When lifting the valve assembly, make sure that the slings attached to the valve body bear the entire load.
- Do not attach load-bearing slings to the actuator, handwheel or any other parts.
- Observe lifting instructions (see Chapter 4.3.2).

### **💡 Tip**

Our after-sales service can provide more detailed transport and lifting instructions on request.

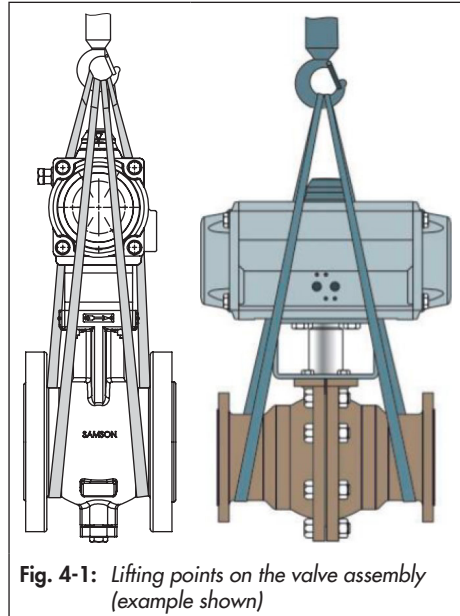

**Fig. 4-1:** Lifting points on the valve assembly (example shown)

### 4.3.1 Transporting the ball valve

The valve assembly can be transported using lifting equipment (e.g. crane or forklift).

- Leave the valve assembly in its transport container or on the pallet to transport it.
- Observe the transport instructions.

#### Transport instructions

- Protect the valve assembly against external influences (e.g. impact).
- Do not damage the corrosion protection (paint, surface coatings). Repair any damage immediately.
- Protect the piping and any mounted valve accessories against damage.

- Protect the valve assembly against moisture and dirt.
- The permissible transportation temperature of standard control valves is  $-20$  to  $+65$  °C/ $-4$  to  $+149$  °F.

---

**i Note**

Contact our after-sales service for the transportation temperatures of other valve versions.

---

### 4.3.2 Lifting the ball valve

To install a large ball valve into the pipeline, use lifting equipment (e.g. crane or forklift) to lift it.

#### Lifting instructions

- Use a hook with safety latch (see Fig. 4-1) to secure the slings from slipping off the hook during lifting and transporting.
- Secure slings against slipping.
- Make sure the slings can be removed from the device once it has been installed into the pipeline.
- Prevent the valve assembly from tilting or tipping.
- Do not leave loads suspended when interrupting work for longer periods of time.
- Make sure that the axis of the pipeline is always horizontal during lifting and the axis of the shaft is always vertical.

#### Lifting the valve assembly

1. Attach one sling to each flange of the body and to the rigging equipment (e.g. hook) of the crane or forklift (see Fig. 4-1).
2. If necessary, attach additional slings that do not bear any load but prevent the valve assembly from turning or tipping over.
3. Carefully lift the valve assembly. Check whether the lifting equipment and accessories can bear the weight.
4. Move the valve assembly at an even pace to the site of installation.
5. Install the valve assembly into the pipeline (see the 'Installation' chapter).
6. After installation in the pipeline, check whether the flanges are bolted tight and the ball valve in the pipeline holds.
7. Remove slings.

### 4.4 Storing the ball valve

---

#### NOTICE

***Risk of damage to the ball valve due to improper storage.***

- ➔ *Observe the storage instructions.*
  - ➔ *Avoid longer storage periods.*
  - ➔ *Contact SAMSON in case of different storage conditions or longer storage times.*
- 

#### Note

*SAMSON recommends to regularly check the valve assembly and the prevailing storage conditions during long storage periods.*

---

#### Storage instructions

- Protect the valve assembly against external influences (e.g. impact).
- Secure the valve assembly in the stored position against slipping or tipping over.
- Do not damage the corrosion protection (paint, surface coatings). Repair any damage immediately.
- Protect the valve assembly against moisture and dirt. Store it at a relative humidity of less than 75 %. In damp spaces, prevent condensation. If necessary, use a drying agent or heating.
- Make sure that the ambient air is free of acids or other corrosive media.
- The permissible storage temperature of standard control valves is  $-20$  to  $+65$  °C/ $-4$  to  $+149$  °F. Contact our

after-sales service for the storage temperatures of other valve versions.

- Do not place any objects on the valve assembly.

#### Special storage instructions for elastomers

Elastomer, e.g. actuator diaphragm

- To keep elastomers in shape and to prevent cracking, do not bend them or hang them up.
  - SAMSON recommends a storage temperature of  $15$  °C ( $59$  °F) for elastomers.
  - Store elastomers away from lubricants, chemicals, solutions and fuels.
- 

#### Tip

*Our after-sales service can provide more detailed storage instructions on request.*

---

## 5 Installation

The work described in this chapter is to be performed only by personnel appropriately qualified to carry out such tasks.

### **⚠ WARNING**

**Crush hazard arising from moving parts.**  
The ball rotates inside the valve body. Crush injuries to hands or fingers may occur if they are inserted into the valve.

- Do not insert hands or fingers into the ball valve body.
- Before working on the valve assembly, release any energy (in the actuator) which causes the shaft to move (e.g. also the spring compression).
- Before working on the valve assembly, disconnect and lock the pneumatic air supply as well as the control signal.
- Disconnect the supply voltage before performing any work on the valve assembly.
- Do not impede the rotary motion of the ball by inserting objects into its path.
- Before attempting to unblock a ball after it has become blocked (e.g. due to seizing up after remaining in the same position for a long time), release any energy (in the actuator) which causes the valve shaft to move.

## 5.1 Installation conditions

### Work position

The work position for the valve assembly is the front view looking onto the operating controls (including valve accessories).

Plant operators must ensure that, after installation of the device, the operating personnel can perform all necessary work safely and easily access the device from the work position.

### Pipeline routing

The inlet and outlet lengths vary depending on several variables and process conditions and lie within the responsibility of the plant engineering company.

To ensure that the valve assembly functions properly, proceed as follows:

- Install the valve assembly free of stress and with the least amount of vibrations as possible. Read information under "Work position" and "Support or suspension" in this chapter.
- Install the valve assembly allowing sufficient space to remove the actuator and ball valve or to perform service and repair work on them.

### Mounting position

The ball valve can be installed in any mounting position. However, we recommend installing the valve assembly with the actuator upright and on top of the valve.

In the following versions, the ball valve must be installed with the actuator on top:

- Valves in NPS 4 and larger

## Installation

- Ball valves with shaft extension or insulating section for low temperatures below  $-10\text{ }^{\circ}\text{C}$  ( $14\text{ }^{\circ}\text{F}$ ).
- ➔ Contact SAMSON if the mounting position is not as specified above.

### Support or suspension

---

#### **i** Note

*The plant engineering company is responsible for selecting and implementing a suitable support or suspension of the installed valve assembly and the pipeline.*

---

Depending on the valve version and mounting position, the ball valve, actuator and pipeline must be supported or suspended. Ball valves, which are not installed with the valve shaft in the vertical position in the pipeline, must be supported or suspended.

### Valve accessories

- ➔ During connection of valve accessories, make sure that they are easily accessible and can be operated safely from the work position.

### Vent plugs

Vent plugs are screwed into the exhaust air ports of pneumatic and electropneumatic devices. They ensure that any exhaust air that forms can be vented to the atmosphere (to avoid excess pressure in the device). Furthermore, the vent plugs allow air intake to prevent a vacuum from forming in the device.

- ➔ Locate the vent plug on the opposite side to the work position of operating personnel.

## 5.2 Preparation for installation

Before installation, make sure the following conditions are met:

- The ball valve is clean.
- The ball valve and all valve accessories (including piping) are not damaged.
- The ball valve data on the nameplate (type designation, nominal size, material, pressure rating and temperature range) match the plant conditions (nominal size and pressure rating of the pipeline, medium temperature etc.). See the 'Markings on the device' chapter for nameplate details.
- The requested or required additional pipe fittings have been installed or prepared as necessary before installing the ball valve.

Proceed as follows:

- ➔ Lay out the necessary material and tools to have them ready during installation work.
- ➔ Flush the pipelines.

#### **i** Note

*The plant operator is responsible for cleaning the pipelines in the plant.*

---

- ➔ Check any mounted pressure gauges to make sure they function properly.
- ➔ When the ball valve and actuator are already assembled, check the tightening torques of the bolted joints. Components may loosen during transport.

## 5.3 Mounting the device

The activities listed below are necessary to install the ball valve and before it can be started up.

### ! NOTICE

**Risk of valve damage due to over- or under-torquing.**

Observe the specified torques when tightening valve components. Excessive tightening torques lead to parts wearing out more quickly. Parts that are too loose may cause leakage.

→ Observe the specified tightening torques.

### ! NOTICE

**Risk of damage to the valve assembly due to the use of unsuitable tools.**

→ Only use tools approved by SAMSON.

### 5.3.1 Mounting the actuator onto the ball valve

#### ! WARNING

**Risk of personal injury due to preloaded springs.**

Actuators with preloaded springs are under tension.

→ Before starting any work on the actuator, relieve the compression from the preloaded springs (see associated actuator documentation).

Depending on the version, SAMSON valves are either delivered with the actuator already mounted on the ball valve or the ball valve and actuator are delivered separately. When delivered separately, the ball valve and actuator must be assembled together on site.

#### Mounting the actuator

→ To mount the actuator, proceed as described in the associated actuator documentation.

### 5.3.2 Installing the ball valve into the pipeline

#### ! NOTICE

**Premature wear and leakage due to insufficient support or suspension.**

→ Support or suspend the valve sufficiently at suitable points.

1. Close the shut-off valves in the pipeline at the inlet and outlet of the plant section while the valve is being installed.
2. Prepare the relevant section of the pipeline for installing the ball valve.
3. Remove the protective caps from the valve ports before installing the ball valve.
4. Make sure that the correct gap is left in the pipeline to accommodate the face-to-face dimension of the valve plus the mounted flange gaskets.
5. Install the ball valve in the fully open position to ensure that the seat and ball

## Installation

sealing surfaces are not damaged during installation.

6. Lift the ball valve using suitable lifting equipment to the site of installation (see section 'Lifting the ball valve' in the 'Shipment and on-site transport' chapter).
7. Make sure that the flange gaskets and fasteners used are suitable for the operating conditions.
8. Bolt the ball valve to the pipeline free of stress.
9. Attach a support or suspension on the valve, if necessary.

### 5.3.3 Connecting the supply air or electrical power to a mounted actuator

- Perform the electrical or pneumatic connection of the actuator as described in the associated actuator documentation.

## 5.4 Testing the installed ball valve

### **⚠ DANGER**

**Risk of bursting due to incorrect opening of pressurized equipment or components.**

Valves and pipelines are pressure equipment that may burst when handled incorrectly. Flying projectile fragments or the release of process medium under pressure can cause serious injury or even death.

Before working on the valve assembly:

- Depressurize all plant sections affected and the ball valve (including the actuator). Release any stored energy.
- Drain the process medium from the plant sections affected as well as from the ball valve.

### **⚠ DANGER**

**Risk of pipes bursting.**

A ball valve that is suddenly opened or closed can cause pressure surges and/or temperature shocks in the pipeline.

- Apply an even and steady pressure to the lever to open and close the ball valve.

### **⚠ WARNING**

**Risk of hearing loss or deafness due to loud noise.**

Noise emission (e.g. cavitation or flashing) may occur during operation caused by the process medium and the operating conditions. Additionally, a loud noise may briefly occur through the sudden venting of the pneumatic actuator or pneumatic valve accessories not fitted with noise-reducing fittings. Both can damage hearing.

- Wear hearing protection when working near the ball valve.



**⚠ WARNING**

**Risk of personal injury due to exhaust air being vented from pneumatically operated components.**

When the ball valve is operated with a pneumatic actuator or pneumatic valve accessories, exhaust air may be vented from the actuator, for example, while the ball valve is operating in closed-loop control or when the ball valve opens or closes.

➔ Wear eye protection when working in close proximity to the valve.

**⚠ WARNING**

**Risk of personal injury due to preloaded springs.**

Actuators with preloaded springs are under tension.

➔ Before starting any work on the actuator, relieve the compression from the preloaded springs (see associated actuator documentation).

To test the ball valve functioning before start-up or putting back the valve into operation, perform the following tests:

### 5.4.1 Leakage

The plant operator is responsible for performing the leak test and selecting the test method. The leak test must comply with the requirements of the national and international standards that apply at the site of installation.

**💡 Tip**

Our after-sales service can support you to plan and perform a leak test for your plant.

1. Close the ball valve.
2. Slowly apply the test medium to the inlet space upstream of the ball valve. A sudden surge in pressure and resulting high flow velocities can damage the ball valve.
3. Open the ball valve.
4. Apply the required test pressure.
5. Check the ball valve for leakage to the atmosphere.
6. Depressurize the pipeline section and ball valve.
7. Rework any parts that leak and repeat the leak test.

### 5.4.2 Rotary motion

The rotary motion of the shaft must be even and smooth.

➔ Apply the maximum and minimum control signals to check the end positions of the ball valve while observing the movement of the shaft.

### 5.4.3 Fail-safe position

- ➔ Shut off the signal pressure line.
- ➔ Check whether the ball valve moves to the fail-safe position (see the 'Design and principle of operation' chapter).

### 5.4.4 Pressure test

The plant operator is responsible for performing the pressure test.

---



#### **Tip**

*Our after-sales service can support you to plan and perform a pressure test for your plant.*

---

During the pressure test, make sure the following conditions are met:

- The ball valve is open.
- Observe the maximum permissible pressure for both the ball valve and plant.

## 6 Start-up

The work described in this chapter is to be performed only by personnel appropriately qualified to carry out such tasks.

### **⚠ DANGER**

#### **Risk of pipes bursting.**

A ball valve that is suddenly opened or closed can cause pressure surges and/or temperature shocks in the pipeline.

- Apply an even and steady pressure to the lever to open and close the ball valve.

### **⚠ WARNING**

#### **Risk of burn injuries due to hot or cold components and pipeline.**

Ball valve components and the pipeline may become very hot or cold.

- Allow components and pipelines to cool down or warm up to the ambient temperature.
- Wear protective clothing and safety gloves.

### **⚠ WARNING**

#### **Risk of hearing loss or deafness due to loud noise.**

Noise emission (e.g. cavitation or flashing) may occur during operation caused by the process medium and the operating conditions. Additionally, a loud noise may briefly occur through the sudden venting of the pneumatic actuator or pneumatic valve ac-

cessories not fitted with noise-reducing fittings. Both can damage hearing.

- Wear hearing protection when working near the ball valve.

### **⚠ WARNING**

#### **Risk of personal injury due to exhaust air being vented from pneumatically operated components.**

When the ball valve is operated with a pneumatic actuator or pneumatic valve accessories, exhaust air may be vented from the actuator, for example, while the ball valve is operating in closed-loop control or when the ball valve opens or closes.

- Wear eye protection when working in close proximity to the valve.

Before start-up or putting the valve back into service, make sure the following conditions are met:

- The valve is properly installed in the pipeline (see the 'Installation' chapter).
- The leak and function tests have been completed successfully (see section 'Testing the installed valve' in the 'Installation' chapter).
- The prevailing conditions in the plant section concerned meet the valve sizing requirements (see section 'Intended use' in the 'Safety instructions and measures' chapter).

## Start-up

### Start-up/putting the device back into operation

1. Allow the ball valve to cool down or warm up to reach ambient temperature before start-up when the ambient temperature and process medium temperature differ greatly or the medium properties require such a measure.
2. Slowly open the shut-off valves in the pipeline. Slowly opening these valves prevents a sudden surge in pressure and high flow velocities which may damage the ball valve.
3. Check the ball valve to ensure it functions properly.

## 7 Operation

Immediately after completing start-up or putting the valve back into operation, the ball valve is ready for use.

---

### **⚠ DANGER**

#### **Risk of pipes bursting.**

A ball valve that is suddenly opened or closed can cause pressure surges and/or temperature shocks in the pipeline.

- ➔ Apply an even and steady pressure to the lever to open and close the ball valve.

---

### **⚠ WARNING**

#### **Risk of burn injuries due to hot or cold components and pipeline.**

Ball valve components and the pipeline may become very hot or cold.

- ➔ Allow components and pipelines to cool down or warm up to the ambient temperature.
- ➔ Wear protective clothing and safety gloves.

---

### **⚠ WARNING**

#### **Risk of hearing loss or deafness due to loud noise.**

Noise emission (e.g. cavitation or flashing) may occur during operation caused by the process medium and the operating conditions. Additionally, a loud noise may briefly occur through the sudden venting of the pneumatic actuator or pneumatic valve accessories not fitted with noise-reducing fittings. Both can damage hearing.

- ➔ Wear hearing protection when working near the ball valve.

---

### **⚠ WARNING**

#### **Risk of personal injury due to exhaust air being vented from pneumatically operated components.**

When the ball valve is operated with a pneumatic actuator or pneumatic valve accessories, exhaust air may be vented from the actuator, for example, while the ball valve is operating in closed-loop control or when the ball valve opens or closes.

- ➔ Wear eye protection when working in close proximity to the valve.

## Operation

### 7.1 Operation with a part-turn actuator

The actuator control unit is used to open and close the ball valve in versions with an electric or pneumatic part-turn actuator.

### 7.2 Manual operation

---

#### **NOTICE**

***Risk of malfunction of the ball valve due to the vibrations caused by the plant.***

→ *If severe plant vibrations are likely to occur, use a locking facility to lock the position of a manually operated ball valve to prevent it from inadvertently opening or closing.*

---

The ball valve with a lever is opened and closed manually.

The lever position indicates the ball bore position. The lever in the standard version is mounted so that it is parallel to the ball bore.

→ Apply an even and steady pressure to the lever to open and close the ball valve.

Do **not** move the lever too quickly. Otherwise, it may lead to pressure surges and/or temperature shocks in the pipeline.

## 8 Malfunctions

Read hazard statements, warnings and caution notes in the 'Safety instructions and measures' chapter.

### 8.1 Troubleshooting

Malfunction	Possible reasons	Recommended action
Shaft does not move on demand.	Initial breakaway torque too high	Shut off the section of the pipeline and flush the ball valve to remove any deposits (dirt or other foreign particles).
	The ball is blocked.	Put the valve assembly out of operation (see the 'Decommissioning' chapter) and remove the blockage. <b>WARNING!</b> A blocked ball can suddenly start to rotate during activities to unblock it. This can lead to crush injuries to hands or fingers if they are inserted into the valve. Before attempting to unblock the ball, release any energy (in the actuator) which causes the shaft to move (e.g. also the spring compression). Disconnect and lock the pneumatic air supply as well as the control signal.
	Diaphragm in the actuator defective (where applicable)	See associated actuator documentation.
	Signal pressure too low (where applicable)	Check the signal pressure. Check the signal pressure line for leakage.
	Incorrect setting of valve accessories (where applicable)	Check the settings of the valve accessories.
Increased flow through closed ball valve (seat leakage)	Dirt or other foreign particle deposits have collected inside the valve.	Shut off the section of the pipeline and flush the ball valve to remove any deposits (dirt or other foreign particles).
	Ball and/or seat rings worn out	Put the valve assembly out of operation (see the 'Decommissioning' chapter) and renew the ball valve.
The ball valve leaks to the atmosphere (fugitive emissions).	O-rings or packing on the shaft worn out and/or body gasket defective	Put the valve assembly out of operation (see the 'Decommissioning' chapter) and renew the ball valve.
	Flanged joint loose or gasket defective	Check the flanged joint. Put the valve assembly out of operation (see the 'Decommissioning' section) and renew the gasket at the flanged joint.

**i Note**

*Contact our after-sales service for malfunctions not listed in the table.*

---

## 8.2 Emergency action

Plant operators are responsible for emergency action to be taken in the plant.

In the event of a ball valve malfunction:

1. Close the shut-off valves upstream and downstream of the ball valve to stop the process medium from flowing through the ball valve.
2. Perform troubleshooting (see Chapter 8.1).
3. Rectify those malfunctions that can be remedied following the information given in this document. Contact our after-sales service in all other cases.

### **Putting the device back into operation after a malfunction**

See the 'Start-up' chapter.



## 9 Servicing

The construction of the Type 3358 Ball Valve is designed so that no service work needs to be performed during its service life.

---

### **!** NOTICE

***Risk of damage to the ball valve due to incorrect maintenance and service work.***

- *Do not perform any service work on your own that requires the ball valve to be dismantled.*
  - *Contact SAMSON's After-sales Service if service work must be performed on the valve.*
- 

### **i** Note

*The valve assembly was checked by SAMSON before it left the factory.*

- *Certain test results certified by SAMSON lose their validity when the ball valve is opened. Such testing includes seat leakage and leak tests.*
  - *The product warranty becomes void if service or repair work not described in these instructions is performed without prior agreement by SAMSON's After-sales Service.*
  - *Only use original spare parts by SAMSON, which comply with the original specifications.*
-

### 9.1 Periodic testing

Depending on the operating conditions, check the valve at certain intervals to prevent possible failure before it can occur. Plant operators are responsible for drawing up an inspection and test plan.

We recommend the following inspection and testing which can be performed while the process is running:

Inspection and testing	Action to be taken in the event of a negative result:
Check the markings, labels and name-plates on the valve assembly for their readability and completeness.	Immediately renew damaged, missing or incorrect name-plates or labels.
	Clean any inscriptions that are covered with dirt and are illegible.
Check the pipe connections and gaskets on the ball valve and actuator for leakage.	Check the flanged joint. Put the valve assembly out of operation (see the 'Decommissioning' section) and renew the gasket at the flanged joint.
Check the ball valve's seat leakage.	Shut off the section of the pipeline and flush the ball valve to remove any deposits (dirt or other foreign particles).
Check the valve assembly for external damage (e.g. corrosion).	Repair any damage immediately. If necessary, put the valve assembly out of operation (see the 'Decommissioning' chapter).
Check the valve accessories to ensure they are mounted properly.	Tighten the connections of the valve accessories.

## 10 Decommissioning

The work described in this chapter is to be performed only by personnel appropriately qualified to carry out such tasks.

### **⚠ DANGER**

**Risk of bursting due to incorrect opening of pressurized equipment or components.**

Valves and pipelines are pressure equipment that may burst when handled incorrectly. Flying projectile fragments or the release of process medium under pressure can cause serious injury or even death.

Before working on the valve assembly:

- Depressurize all plant sections affected and the ball valve (including the actuator). Release any stored energy.
- Drain the process medium from the plant sections affected as well as from the ball valve.

### **⚠ DANGER**

**Risk of pipes bursting.**

A ball valve that is suddenly opened or closed can cause pressure surges and/or temperature shocks in the pipeline.

- Apply an even and steady pressure to the lever to open and close the ball valve.

### **⚠ WARNING**

**Risk of burn injuries due to hot or cold components and pipeline.**

Ball valve components and the pipeline may become very hot or cold.

- Allow components and pipelines to cool down or warm up to the ambient temperature.
- Wear protective clothing and safety gloves.

### **⚠ WARNING**

**Risk of hearing loss or deafness due to loud noise.**

Noise emission (e.g. cavitation or flashing) may occur during operation caused by the process medium and the operating conditions. Additionally, a loud noise may briefly occur through the sudden venting of the pneumatic actuator or pneumatic valve accessories not fitted with noise-reducing fittings. Both can damage hearing.

- Wear hearing protection when working near the ball valve.

### **⚠ WARNING**

**Crush hazard arising from moving parts.**

The ball rotates inside the valve body. Crush injuries to hands or fingers may occur if they are inserted into the valve.

- Do not insert hands or fingers into the ball valve body.
- Before working on the valve assembly, release any energy (in the actuator) which causes the shaft to move (e.g. also the spring compression).
- Before working on the valve assembly, disconnect and lock the pneumatic air supply as well as the control signal.

## Decommissioning

- *Disconnect the supply voltage before performing any work on the valve assembly.*
  - *Do not impede the rotary motion of the ball by inserting objects into its path.*
  - *Before attempting to unblock a ball after it has become blocked (e.g. due to seizing up after remaining in the same position for a long time), release any energy (in the actuator) which causes the valve shaft to move.*
- 

### **WARNING**

#### ***Risk of personal injury due to exhaust air being vented from pneumatically operated components.***

*When the ball valve is operated with a pneumatic actuator or pneumatic valve accessories, exhaust air may be vented from the actuator, for example, while the ball valve is operating in closed-loop control or when the ball valve opens or closes.*

- *Wear eye protection when working in close proximity to the valve.*
- 

### **WARNING**

#### ***Risk of personal injury due to residual process medium in the ball valve.***

*While working on the ball valve, residual medium can flow out of the valve and, depending on its properties, cause personal injury, e.g. (chemical) burns.*

- *Wear protective clothing, safety gloves, respiratory protection and eye protection.*
- 

To decommission the valve assembly for service work or to remove it from the pipeline, proceed as follows:

1. Close the shut-off valves upstream and downstream of the ball valve to stop the process medium from flowing through the ball valve.
2. Completely drain the pipelines and ball valve. To do this, open the ball valve.
3. Disconnect and lock the pneumatic air supply and/or electrical power (if applicable) to depressurize the valve assembly.
4. Release any stored energy.
5. If necessary, allow the pipeline and valve components to cool down or warm up to the ambient temperature.

## 11 Removal

The work described in this chapter is to be performed only by personnel appropriately qualified to carry out such tasks.

### **⚠ WARNING**

#### **Risk of burn injuries due to hot or cold components and pipeline.**

Ball valve components and the pipeline may become very hot or cold.

- Allow components and pipelines to cool down or warm up to the ambient temperature.
- Wear protective clothing and safety gloves.

### **⚠ WARNING**

#### **Crush hazard arising from moving parts.**

The ball rotates inside the valve body. Crush injuries to hands or fingers may occur if they are inserted into the valve.

- Do not insert hands or fingers into the ball valve body.
- Before working on the valve assembly, release any energy (in the actuator) which causes the shaft to move (e.g. also the spring compression).
- Before working on the valve assembly, disconnect and lock the pneumatic air supply as well as the control signal.
- Disconnect the supply voltage before performing any work on the valve assembly.
- Do not impede the rotary motion of the ball by inserting objects into its path.

- Before attempting to unblock a ball after it has become blocked (e.g. due to seizing up after remaining in the same position for a long time), release any energy (in the actuator) which causes the valve shaft to move.

### **⚠ WARNING**

#### **Risk of personal injury due to residual process medium in the ball valve.**

While working on the ball valve, residual medium can flow out of the valve and, depending on its properties, cause personal injury, e.g. (chemical) burns.

- Wear protective clothing, safety gloves, respiratory protection and eye protection.

### **⚠ WARNING**

#### **Risk of personal injury due to preloaded springs.**

Actuators with preloaded springs are under tension.

- Before starting any work on the actuator, relieve the compression from the preloaded springs (see associated actuator documentation).

Before removing the valve, make sure the following conditions are met:

- The valve assembly is put out of operation (see the 'Decommissioning' chapter).

## Removal

### **11.1 Removing the ball valve from the pipeline**

1. Support the valve to hold it in place when separated from the pipeline (see the 'Shipment and on-site transport' chapter).
2. Unbolt the flanged joint.
3. Remove the ball valve from the pipeline (see the 'Shipment and on-site transport' chapter).

### **11.2 Removing the actuator from the valve**

See associated actuator documentation.

## 12 Repairs

If the valve does not function properly according to how it was originally sized or does not function at all, it is defective and must be repaired or exchanged.

---

### ! NOTICE

**Risk of damage to the ball valve due to incorrect service or repair work.**

- Do not perform any repair work on your own.
  - Contact SAMSON's After-sales Service for service and repair work.
- 

---

### i Note

Further information on returned devices and how they are handled can be found at  
▶ [www.samsongroup.com](http://www.samsongroup.com) > Service > After-sales Service.

---

### 12.1 Returning devices to SAMSON

Defective devices can be returned to SAMSON for repair.

- Contact SAMSON CONTROLS PVT. LTD. in India **beforehand** to find out the procedure on how to return them.
- Decontaminate the device properly before shipping it.
- Include the material safety data sheet of the process medium as well as the decontamination certificate in the return shipment.





## 13 Disposal

- Observe local, national and international refuse regulations.
- Do not dispose of components, lubricants and hazardous substances together with your household waste.



## 14 Certificates

The following declarations of conformity are included on the next pages:

- IBR (Indian Boiler Regulations)
- API 607 (fire-safe version)
- ISO 10497 (fire-safe version)
- API 6FA (fire-safe version)
- EN ISO 15848-1 (fugitive emissions)

The certificates shown were up to date at the time of publishing.

Other optional certificates are available on request.



Government of Maharashtra

Department of Labor

Evaporators Directorate



Apan Mahav of Khana

☎ 022-26571201 / 1304 / 1352 Kamgar Bhawan, 7th Floor, Plot no. C-20, Block-E.

☎ 022-26571283

Bandra-Kurla Complex, Bandra (East), Mumbai- 400051.

E-mail: [dirsb.mumbai@maharashtra.gov.in](mailto:dirsb.mumbai@maharashtra.gov.in), <https://mahakamgar.maharashtra.gov.in>, <http://www.mahaboiler.in>

No. : SB-5/NSK / 2023 / 1422)

Dated -

8 SEP 2023

per,

May Samson Controls Pvt. Ltd.  
D - 281, MIDC Ranjangaon, Pt.  
Shirur, Dist. Pune- 412220

Subject :- Regarding the renewal of the approval granted for the manufacture  
of "Valve"

Reference :- Letter No. 1 of this office ) SB-5/ MBD /2009/23105, dt. 14.10.2009

2) SB-5/NSK/2020/10291, dt. 14.12.2020

Sir,

With reference to your letter No.- SCPL/QA/PJ /2022/1, dated 22.12.2022,  
you are hereby informed that through the above referred letter of this office to you  
under the supervision of this department "Valve" Cast / Forged as per Indian  
Steamers Regulations, 1950 Manufacturing of valves (Size up to 500mm NB) was given  
conditional approval. It is now only on the condition of the letter of this office mentioned  
above, dt. It is being extended till 31 December 2023.

It is also to be informed that the application for further renewal, the above deadline

To be submitted at least 30 days prior to expiry.

Yours faithfully,

(D.P. Antapurkar)  
director,

Vapike, Maharashtra State, Mumbai.

Copy :-

Joint Director, Evaporators, Maharashtra State, Pune/Nagpur/Ahmednagar/Nashik/Kolhapur/Solapur



महाराष्ट्र शासन  
कामगार विभाग  
वाष्पके संचालनालय

☎ ०२२-२६५७९२०९ / ९३०४ / ९३५२ कामगार भवन, ७ वा मजला, प्लॉट क्र. सी- २०, ब्लॉक- ई,

☎ ०२२-२६५७९२८३ वांद्रे-कुर्ला संकुल, वांद्रे (पू), मुंबई- ४०० ०५९.

E-mail: dirsb.mumbai@maharashtra.gov.in, https://mahakamgar.maharashtra.gov.in, http://www.mahaboiler.in

कमांक :एसवी-५/एनएसके/२०२३/ १४२२)

दिनांक

प्रति,

- 8 SEP 2023

मे. सॅमसन कंट्रोल्स प्रा. लि.  
डी-२८१, एमआयडीसी संजणगांव,  
ता. शिरूर, जि. पुणे- ४१२ २२०

विषय :- "व्हॉल्वस" च्या निर्मितीकरिता देण्यात आलेल्या मान्यतेचे नुतनीकरण करण्याबाबत

संदर्भ :- या कार्यालयाचे पत्र कमांक- 1) SB-5/MBD/2009/23105, दिनांक.१४.१०.२००९  
2) SB-5/NSK/2020/10291, दिनांक.१४.१२.२०२०

महोदय,

आपले पत्र कमांक- SCPL/QA/PJ/2022/1, दिनांक २२.१२.२०२२, च्या संदर्भात आपणांस कळविण्यात येते की, या कार्यालयाचे उपरोक्त संदर्भित पत्राद्वारे आपणांस या विभागाच्या पर्यवेक्षणाखाली भारतीय वाष्पक विनियम, १९५० नुसार "व्हॉल्वस" कास्ट/फोर्ज व्हॉल्वस (Size up to 500 mm NB) ची निर्मिती करण्यास विहित अटीवर मान्यता देण्यात आली होती. ती आता उपरोक्त नमुद केलेल्या या कार्यालयाच्या पत्रातील अटीवरच, दि. ३१ डिसेंबर २०२३ पर्यंत वाढविण्यात येत आहे.

तसेच कळविण्यात येते की, पुढील नुतनीकरणाबाबतचा अर्ज, वरील मुदत समाप्तीच्या किमान ३० दिवस अगोदर सादर करावा.

आपला विश्वासू,

(ध.प्र.अतापूरकर)  
संचालक,

वाष्पके, महाराष्ट्र राज्य, मुंबई.

प्रत :-

सहसंचालक, वाष्पके, महाराष्ट्र राज्य, पुणे/नागपूर/अहमदनगर/नाशिक/कोल्हापूर/सोलापूर

## API STD 607 FIRE TYPE TEST CERTIFICATE

Conformity with Fire Type-Test

Acc. to API STD 607, 8<sup>TH</sup> EDITION, OCTOBER 2022

Test Certificate No: PITS/FTT/607/SAMSON/CERT/001

Date: 26<sup>th</sup> March, 2023

Name & Address of the Valve Manufacturer

**SAMSON CONTROLS PRIVATE LIMITED**

D-281, MIDC, RANJANGAON, TALUKA SHIRUR, KAREGAON, PUNE, MAHARASHTRA, 412220, INDIA

Name & Address of the Testing Facility

**PURVA INSPECTION & TESTING SERVICES**

16, SATYAM ESTATE, STEEL TOWN, BESIDE HOF, MORAIYA, CHANGODAR, AHMEDABAD, PIN CODE: 382 213, GUJARAT, INDIA

- We hereby certify that the results of Valve Tests carried out under witness of M's LRQA (TPIA) on the Industrial Valve below meeting the requirements in the standard mentioned above. The fire-tested valve has passed all the required hydrostatic, air type and production pressure tests required by the design & Manufacturing standard as listed below. For detailed Valve technical data and information refer to the Test Report.

Type of Valve (Description of Tested Valve)	DESIGN AS PER ISO 17292:2015; ASME B16.34-2020 FULL BORE 2 PIECE BALL VALVE, LEVER OPERATED- FLANGE END RF THE VALVE IS SYMMETRIC AND INTENDED FOR BIDIRECTIONAL INSTALLATION.		
Size & Pressure Class of Valve	NPS 2 (DN 50); CLASS 150		
Assembly Drawing No.	FBV-0210A-FFR-57G01B-J; REV 0	Valve Sr. No.	890-129394
Material of Construction (MOC)	ASTM A351 GR CF8M (BODY, ADAPTOR); SS 316 (GLAND; DISC SPRING) A4-70 (SPRING WASHER; LOCK NUT; LOCK WASHER); ASTM A182 GR 316 (STOPPER PIN)		
Ball Material	ASTM A182 GR F316	Stem Material	ASTM A479 GR 316
Seat Material	TFM 16000	Body Seal / Gasket Material	GRAPHITE
Stem Seal / Packing Material	BRAIDED GRAPHITE & GRAPHITE	O-Ring Material	CHEMRAZ 605
Fasteners Material	HEX BOLT: A4-70	Thrust Washer Material	PTFE
Weight of Valve	≈ 8.75 kg The type of valve body ends are not considered by this International Standard. However, the mass of the valve is determined in part by the body and type. For qualification to the present International Standard, and providing that all other qualification criteria have been met, valves with ends different to those of the test valve may also qualify provided that their mass is greater than that of the test valve, or their mass is not less than 75% of that of the test valve.		
Test Report No	PITS/FTT/607/SAMSON/RP/001		
Test Result	PASS		
Qualified Range	This test for particular valve also qualifies following sizes and pressure class rating & Materials of Construction as per API STD 607, 8 <sup>TH</sup> ED, OCTOBER 2022, Clause 7		
Nominal Diameter Qualified	NPS 2 AND BELOW; 2 1/2; 3; 4 or DN 50 AND BELOW; 65; 80; 100		
Nominal Pressure Class Qualified	Qualified valves with higher PN or Class Ratings but not exceeding twice the PN or Class Rating of the tested Valve. Class Rating 150 & 300 or PN 10; 16; 25 & 40		
Non-metallic Materials	TFM 16000 (SEAT); CHEMRAZ 605 (O-RING); PTFE (THRUST WASHER)		
Further Qualification	Any change in non-metallic materials with respect to the seat-to-closure member seal, seat-to-body seal, stem seal, and body joint seal require a re-qualification.		
Declaration	The tested valve complied with the requirements of API STD 607, 8 <sup>TH</sup> ED, OCTOBER 2022		



For, Purva Inspection & Testing Services  
Dhaval Chauhan



Test Witnessed By  
Pinkesh Parmar (TPIA) (M's LRQA)

**Notes:**

- If the location of the valve manufacturing facilities is different than what is listed on the API STD 607, 8<sup>TH</sup> ED, OCTOBER 2022 certificate, the purchaser may request requalification.
- This certificate is issued according to API STD 607, 8<sup>TH</sup> ED, OCTOBER 2022, based upon the results of testing report on above mentioned test valve. The additional valve qualification shall be limited on similar valves of the same basic design (type, model, and/or configuration) and construction as the same test valve and of the same non-metallic material as the test valve in the seat-to-closure member seal, seat-to-body seal, stem seal and body joint seal according to API STD 607, 8<sup>TH</sup> ED, OCTOBER 2022, Clause No 7

Page 1 of 1

3 New Tirupati Society,  
Nr. Radhaswami Satsang,  
Ranip, Ahmedabad - 382480



info@purvainspection.com  
dhaval@purvainspection.com



+91 9904 004187  
+91 9824 004187





**ISO 10497 FIRE TYPE TEST CERTIFICATE**  
**Conformity with Fire Type-Test**  
**Acc. to ISO 10497, 4<sup>TH</sup> EDITION, OCTOBER 2022**

Test Certificate No: PITS/FTT/10497/SAMSON/CERT/004

Date: 16<sup>TH</sup> OCTOBER 2023

**Name & Address of the Valve Manufacturer**  
**SAMSON CONTROLS PRIVATE LIMITED**

D-281, MIDC, RANJANGAON, TALUKA SHIRUR, KAREGAON, PUNE, MAHARASHTRA, 412220, INDIA

**Name & Address of the Testing Facility**  
**PURVA INSPECTION & TESTING SERVICES**

16, SATYAM ESTATE, STEEL TOWN, BESIDE HOF, MORAIYA, CHANGODAR, AHMEDABAD, PIN CODE: 382 213, GUJARAT, INDIA

- We hereby certify that the results of Valve Tests carried out under witness of M/s DNV (TPIA) on the Industrial Valve below meeting the requirements in the standard mentioned above. The fire-tested valve has passed all the required hydrostatic, air type and production pressure tests required by the design & Manufacturing standard as listed below. For detailed Valve technical data and information refer to the Test Report.

Type of Valve (Description of Tested Valve)	DESIGN AS PER: ISO 17292:2015; ASME B16.34-2020 FULL BORE 2 PIECE SOFT SEATED FLOATING BALL VALVE; FLANGE END (RF); LEVER OPERATED THE VALVE IS SYMMETRIC AND INTENDED FOR BIDIRECTIONAL INSTALLATION.
Size & Pressure Class of Valve	NPS 2 (DN 50); CLASS 150
Model No.	3358 BALL VALVE
Assembly Drawing No.	FBV-0201A-FFR-STG011B-J; REV: 0
Valve Sr. No.	SAMPLE-1
Material of Construction (MOC)	ASTM A351 GR CF3M (BODY & ADAPTOR); SS 316 (GLAND; DISC SPRING); ASTM A182 GR F316 (STOPPER PIN)
Ball Material	ASTM A182 GR F316L
Stem Material	ASTM A479 GR 316L
Seat Material	TFM 1600
Body Seal / Gasket Material	GRAPHITE
Stem Seal / Packing Material	BRAIDED GRAPHITE & GRAPHITE
Fasteners Material	A4-70 (HEX BOLT); A4-70 (SPRING WASHER; LOCK NUT; LOCK WASHER)
Other Soft Material	FKM (O-RING); PTFE (THRUST WASHER)
Weight of Valve	= 9 kg The type of valve body ends is not considered by this International Standard. However, the mass of the valve is determined in part by the body end type. For qualification to the present International Standard, and providing that all other qualification criteria have been met, valves with ends different to those of the test valve may also qualify provided that their mass is greater than that of the test valve, or their mass is not less than 75% of the test valve.
Test Report No	PITS/FTT/10497/SAMSON/RP/004
Test Result	PASS
Declaration	The tested valve complied with the requirements of ISO 10497, 4 <sup>TH</sup> ED, OCTOBER 2022



For, Purva Inspection & Testing Services  
 Dhaval Chauhan

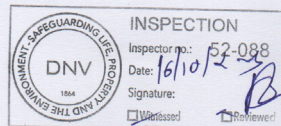

Test Witnessed By  
 Bhavin Naliyapara (TPIA) (M/s DNV)



**API STD 6FA FIRE TYPE TEST CERTIFICATE**  
Conformity with Fire Type-Test  
Acc. to API STD 6FA, 5<sup>TH</sup> EDITION, MAY 2020

Test Certificate No: PITS/FTT/6FA/SAMSON/CERT/005

Date: 16<sup>TH</sup> OCTOBER 2023

**Name & Address of the Valve Manufacturer**  
**SAMSON CONTROLS PRIVATE LIMITED**

D-281, MIDC, RANJANGAON, TALUKA SHIRUR, KAREGAON, PUNE, MAHARASHTRA, 412220, INDIA

**Name & Address of the Testing Facility**  
**PURVA INSPECTION & TESTING SERVICES**

16, SATYAM ESTATE, STEEL TOWN, BESIDE HOF, MORAIYA, CHANGODAR, AHMEDABAD, PIN CODE: 382 213, GUJARAT, INDIA

- We hereby certify that the results of Valve Tests carried out under witness of M/s DNV (TPIA) on the Industrial Valve below meeting the requirements in the standard mentioned above. The fire-tested valve has passed all the required hydrostatic, air pressure and production pressure tests required by the design & Manufacturing standard as listed below. For detailed Valve technical data and information refer to the Test Report.

Type of Valve (Description of Tested Valve)	DESIGN AS PER: ISO 17292:2015; ASME B16.34-2020 FULL BORE 2 PIECE SOFT SEATED FLOATING BALL VALVE; FLANGE END (RF); LEVER OPERATED THE VALVE IS SYMMETRIC AND INTENDED FOR BIDIRECTIONAL INSTALLATION
Size & Pressure Class of Valve	NPS 2 (DN 50); CLASS 150
Model No.	3358 BALL VALVE
Assembly Drawing No.	FBV-0201A-FFR-STGO11B-J; REV: 0
Valve Serial No.	SAMPLE-2
Material of Construction (MOC)	ASTM A351 GR CF3M (BODY & ADAPTOR); SS 316 (GLAND; DISC SPRING); ASTM A182 GR F316 (STOPPER PIN)
Ball Material	ASTM A182 GR F316L
Stem Material	ASTM A479 GR 316L
Seat Material	TFM 1600
Body Seal / Gasket Material	GRAPHITE
Stem Seal / Packing Material	BRAIDED GRAPHITE & GRAPHITE
Fasteners Material	A4-70 (HEX BOLT); A4-70 (SPRING WASHER; LOCK NUT; LOCK WASHER)
Other Soft Material	FKM (O-RING); PTFE (THRUST WASHER)
Weight of Valve	≈ 9 kg
Test Report No	PITS/FTT/6FA/SAMSON/RP/005
Test Result	PASS
Declaration	The tested valve complied with the requirements of API STD 6FA, 5 <sup>TH</sup> ED, MAY 2020

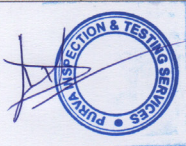

For, Purva Inspection & Testing Services  
Dhaval Chauhan



Test Witnessed By  
Bhavini Naliyapara (TPIA) (M/s DNV)





**ISO 15848 PART 1: FUGITIVE EMISSION TYPE TEST CERTIFICATE**  
Conformity with Fugitive Emission Testing  
Acc. to BS EN ISO 15848-1: 2015 + A1: 2017

**Certificate No.:** PITS-FET-15848-P1-SAMSON-CERT-001

**Date:** 21/12/2023

**Test Dates:** 18/12/2023 to 21/12/2023

**Name & Address of the Valve Manufacturer**  
SAMSON CONTROLS PRIVATE LIMITED

D-281, MIDC, RANJANGAON, TALUKA SHIRUR, KAREGAON, PUNE, MAHARASHTRA, 412220, INDIA

**Name & Address of the Testing Facility**  
PURVA INSPECTION & TESTING SERVICES

16, SATYAM ESTATE, STEEL TOWN, BESIDE HOF, MORAIYA, CHANGODAR, AHMEDABAD, GUJARAT, PIN CODE: 382213, INDIA

We hereby certify that the results of Valve Tests carried out under witness of M/s DNV (TPIA) on the Industrial Valve below meeting the requirements in the standard mentioned above. For detailed Valve technical data and information refer to the Test Report.

**1. Valve Details:**

Valve Type & Size	FLOATING TYPE BALL VALVE, FULL BORE, BI-DIRECTIONAL, 2 PIECE, QUARTER TURN, FLANGE ENDS-RF, LEVER OPERATED, DESIGN: ISO 17292:2015, ASME B16.34-2020 NPS 2 (50 MM), CLASS 150 (PN 20)
Valve Model	3358
Valve Style	FLOATING TYPE, FULL BORE, BI-DIRECTIONAL, 2 PIECE, QUARTER TURN
Drawing No	FBV-0201A-FFR-STG011B-J
Valve Sr. No.	SAMPLE-2
Material of Construction	ASTM A351 GR CF3M (BODY, ADAPTOR); ASTM A182 GR F316 (BALL); A4-70 (SPRING WASHER, HEX BOLT, LOCK NUT, LOCK WASHER)
Heat No.	L271P (BODY); L254P (ADAPTOR); 21L1185 (STEM)
Seat Ring	TFM 1600
Other Soft Materials	FRM (O-RING); PTFE (THRUST WASHER)
Stem or Shaft Seal (Gland Packing) (Bonnet Packing)	EXPANDED GRAPHITE METALLIC PACKING REINFORCED (BRAIDED) WITH INCONEL WIRE (MODEL: 100 FXI STYLE OF INMARCO) DIMENSIONS: 25.0 MM OD X 19.0 MM ID X 3.0 MM THK.; 5 QTY
Body-Adaptor Seal(s): Gasket	GRAPHITE; DIMENSIONS: 95.0 MM OD X 88.0 MM ID X 3.0 MM THK
Material specifications of stem (or shaft) seal components	SS 316 (GLAND, DISC SPRING)
Stem Diameter	19.0 mm
Stem Material Specification	ASTM A479 GR 316
Gland Bolt Tightening Torque	16 N-m
Stroke Length / Angle	90°
Testing Temperature	AMBIENT (ROOM TEMPERATURE) (RT) (+5° C to +40° C) TO 200° C RATED PRESSURE SPECIFIED AT THE TEST TEMPERATURE
Test Pressure	AT RT: 20 kg/cm <sup>2</sup> g; AT 200°C TEMP: 15 kg/cm <sup>2</sup> g
Valve Mounting Position	STEM HORIZONTAL
Mechanical & Thermal Cycle	2500 CYCLES (FULL STROKE) WITH FOUR THERMAL CYCLES
Valve Performance Class	C03
Method of Sample Selection	RANDOMLY SELECTED FROM THE PRODUCTION
Valve Mounting Instructions	NOT APPLICABLE

**2. Test Fluid:** Helium Gas of 99.99% purity



TESTED BY:  
FOR PURVA INSPECTION & TESTING SERVICES  
DHAVAL CHAUDHAN  
(NDT LEVEL II- MASS SPECTROMETER LEAK TESTING)



**WITNESSED BY:**

Bhavin Naliyapara (TPIA) (M/s DNV)





## 15 Appendix

### 15.1 Tightening torques, lubricants and tools

#### Tightening torques

**Table 15-1:** *Tightening torques for screws (10) to connect body halves in Nm*

Nominal size		NPS	1	1½	2	3	4	6
Tightening torques	Class 150	Nm	15	27	35	82	148	360
	Class 300	Nm	19	35	48	117	192	570

#### Lubricants

Lubricants to be used depend on the ball valve material and the individual application. The lubricants can be purchased from SAMSON.

→ Contact our after-sales service.

#### Tools

In addition to the standard tools expected to be available, special tools are required to assemble and remove some parts. Use adjustable torque wrenches with a stop signal or that indicate the torque being applied to achieve the right tightening torques. The required special tools can be purchased from SAMSON.

→ Contact our after-sales service.

### 15.2 After-sales service

Contact our after-sales service for support concerning service or repair work or when malfunctions or defects arise.

#### E-mail address

You can reach our after-sales service at [info@samsoncontrols.net](mailto:info@samsoncontrols.net).

#### SAMSON India

SAMSON CONTROLS PVT. LTD.  
D-281, MIDC Ranjangaon, Taluka Shirur  
District Pune 412220, Maharashtra, INDIA  
Phone: +91 2138 665 600  
Fax: +91 2138 665 666

#### Addresses of SAMSON AG and its subsidiaries

The addresses of SAMSON AG, its subsidiaries, representatives and service facilities worldwide can be found on our website ([www.samsongroup.com](http://www.samsongroup.com)).

#### Required specifications

Please submit the following details:

- Order number and position number in the order
- Type, model number, nominal size and version of the ball valve
- Pressure and temperature of the process medium
- Flow rate in m<sup>3</sup>/h
- Bench range of the actuator (e.g. 0.2 to 1 bar), if mounted
- Is a strainer installed?
- Installation drawing







**EB 9910 EN**



SAMSON CONTROLS PVT. LTD.  
D-281, MIDC Ranjangaon, Taluka Shirur  
District Pune 412220, Maharashtra · India  
Phone: +91 2138 665 600 · Fax: +91 2138 665 666  
info@samsoncontrols.net · www.samsongroup.com