

MOUNTING AND OPERATING INSTRUCTIONS



EB 3963 EN

Translation of original instructions



Type 3963 Solenoid Valves

Edition January 2022

CE **EAC** **Ex**
certified

Note on these mounting and operating instructions

These mounting and operating instructions assist you in mounting and operating the device safely. The instructions are binding for handling SAMSON devices. The images shown in these instructions are for illustration purposes only. The actual product may vary.

- For the safe and proper use of these instructions, read them carefully and keep them for later reference.
- If you have any questions about these instructions, contact SAMSON's After-sales Service (aftersaleservice@samsongroup.com).



Documents relating to the device, such as the mounting and operating instructions, are available on our website at www.samsongroup.com > **Service > Documentation**.

Definition of signal words

DANGER

Hazardous situations which, if not avoided, will result in death or serious injury

WARNING

Hazardous situations which, if not avoided, could result in death or serious injury

NOTICE

Property damage message or malfunction

Note

Additional information

Tip

Recommended action

1	Safety instructions and measures	5
1.1	Notes on possible severe personal injury	8
1.2	Notes on possible personal injury	8
1.3	Notes on possible property damage	9
2	Markings on the device	10
2.1	Nameplate	10
2.2	Article code	11
3	Design and principle of operation	15
3.1	Accessories	17
3.2	Technical data	20
3.3	Dimensions in mm	28
4	Measures for preparation	42
4.1	Unpacking	42
4.2	Storage	42
5	Mounting and start-up	42
5.1	Mounting	43
5.1.1	Rail mounting	43
5.1.2	Wall mounting	44
5.1.3	Mounting on rotary actuators with NAMUR interface	44
5.1.4	Mounting to linear actuators with NAMUR rib	46
5.1.5	Mounting on linear actuators using CrNiMo steel pipe fitting	46
5.1.6	Mounting on mounting block for SAMSON Type 3277 Pneumatic Actuator	46
5.2	Pneumatic connection	48
5.2.1	Sizing of the connecting line	48
5.2.2	Compressed air quality	49
5.3	Changeover to external pilot supply over port 9	50
5.4	Exhaust air feedback	52
5.5	Restrictors	52
6	Electrical connection	53
6.1	Switching amplifier according to EN 60079-25	54
6.2	Cable entry with cable gland	54
6.3	Connecting the electrical supply	54
7	Operation	55
7.1	Degree of protection	55
7.2	Manual override	55

Contents

8	Servicing.....	57
8.1	Preparation for return shipment.....	57
9	Malfunctions	58
9.1	Emergency action	58
10	Decommissioning and removal	58
10.1	Decommissioning.....	58
10.2	Disposal.....	59
11	Appendix.....	59
11.1	After-sales Service	59

1 Safety instructions and measures

Intended use

The Type 3963 Solenoid Valve is mounted onto pneumatic linear or rotary actuators (depending on the version) to control them. Upon failure of the air supply, the solenoid valve vents the actuator, causing the valve to move to the fail-safe position determined by the actuator. The device is designed to operate under exactly defined conditions (e.g. operating pressure, temperature). Therefore, operators must ensure that the solenoid valve is only used in applications where the operating conditions correspond to the technical data. In case operators intend to use the solenoid valve in applications or conditions other than those specified, contact SAMSON.

SAMSON does not assume any liability for damage resulting from the failure to use the device for its intended purpose or for damage caused by external forces or any other external factors.

➔ Refer to the technical data and nameplate for limits and fields of application as well as possible uses.

Reasonably foreseeable misuse

The solenoid valve is **not** suitable for the following applications:

- Use outside the limits defined during sizing and by the technical data

Furthermore, the following activities do not comply with the intended use:

- Use of non-original spare parts
- Performing maintenance activities not described

Qualifications of operating personnel

The solenoid valve must be mounted, started up, serviced and repaired by fully trained and qualified personnel only; the accepted industry codes and practices must be observed.

According to these mounting and operating instructions, trained personnel refers to individuals who are able to judge the work they are assigned to and recognize possible hazards due to their specialized training, their knowledge and experience as well as their knowledge of the applicable standards.

Explosion-protected versions of this device must be operated only by personnel who has undergone special training or instructions or who is authorized to work on explosion-protected devices in hazardous areas.

Safety instructions and measures

Personal protective equipment

Personal protective equipment is not required to mount or operate the solenoid valve. Work on the control valve may be necessary when mounting or removing the solenoid valve.

- ➔ Observe the requirements for personal protective equipment specified in the valve documentation.
- ➔ Check with the plant operator for details on further protective equipment.

Revisions and other modifications

Revisions, conversions or other modifications of the product are not authorized by SAMSON. They are performed at the user's own risk and may lead to safety hazards, for example. Furthermore, the product may no longer meet the requirements for its intended use.

Warning against residual hazards

The solenoid valve has a direct influence on the control valve when it has been installed. To avoid personal injury or property damage, plant operators and operating personnel must prevent hazards that could be caused in the control valve by the process medium, the operating pressure, the signal pressure or by moving parts by taking appropriate precautions. Plant operators and operating personnel must observe all hazard statements, warning and caution notes in these mounting and operating instructions, especially for installation, start-up and service work.

Responsibilities of the operator

Operators are responsible for proper use and compliance with the safety regulations. Operators are obliged to provide these mounting and operating instructions as well as the referenced documents to the operating personnel and to instruct them in proper operation. Furthermore, operators must ensure that operating personnel or third parties are not exposed to any danger.

Responsibilities of operating personnel

Operating personnel must read and understand these mounting and operating instructions as well as the referenced documents and observe the specified hazard statements, warnings and caution notes. Furthermore, operating personnel must be familiar with the applicable health, safety and accident prevention regulations and comply with them.

Servicing explosion-protected devices

If a part of the device on which the explosion protection is based needs to be serviced, the device must not be put back into operation until a qualified inspector has assessed it according to explosion protection requirements, has issued an inspection certificate, or given

the device a mark of conformity. Inspection by a qualified inspector is not required if the manufacturer performs a routine test on the device before putting it back into operation and the passing of the routine test is documented by attaching a mark of conformity to the device. Replace explosion-protected components only with original, routine-tested components by the manufacturer.

Devices that have already been operated outside hazardous areas and are intended for future use inside hazardous areas must comply with the safety requirements placed on serviced devices. Before being operated inside hazardous areas, test the devices according to the specifications for servicing explosion-protected devices.

Maintenance, calibration and work on equipment

- ➔ Only use intrinsically safe current/voltage calibrators and measuring instruments for interconnection with intrinsically safe circuits to check or calibrate the equipment inside or outside hazardous areas.
- ➔ Observe the maximum permissible values specified in the certificates for intrinsically safe circuits.

Referenced standards, directives and regulations

Devices with a CE marking fulfill the following requirements of the Directives:

- Type 3963-0: 2014/30/EU, 2014/35/EU, 2011/65/EU, 2015/863/EU
- Type 3963-1/-8: 2014/30/EU, 2014/34/EU, 2011/65/EU 2015/863/EU

Devices with an EAC marking fulfill the requirements of the Regulations TR CU 004/2011 and TR CU 020/2011.

See Chapter 11 for declarations of conformity and EAC certificates.

Referenced documentation

The following documents apply in addition to these mounting and operating instructions:

- The mounting and operating instructions of the components on which the solenoid valve is mounted (valve, actuator, valve accessories etc.)
- Safety manual of the solenoid valve ► SH 3963

1.1 Notes on possible severe personal injury

DANGER

Risk of fatal injury due to electric shock.

Before starting up the solenoid valve, electrical installation work must be performed. An electric shock due to incorrect work practices may cause death.

- Before connecting wiring, performing any work on the device or opening the device, disconnect the supply voltage and protect it against unintentional reconnection.
- For electrical installation, observe the relevant electrotechnical regulations and the accident prevention regulations that apply in the country of use.
- In Germany, observe the VDE regulations and the accident prevention regulations of the employers' liability insurance.

Risk of fatal injury due to the ignition of an explosive atmosphere.

Incorrect installation, operation or maintenance of the solenoid valve in potentially explosive atmospheres may lead to ignition of the atmosphere and ultimately to death.

- The following regulations apply to installation in hazardous areas: EN 60079-14: 2008 (VDE 0165, Part 1).
- Installation, operation or maintenance of the solenoid valve must only be performed by personnel who has undergone special training or instructions or who is authorized to work on explosion-protected devices in hazardous areas.
- Observe the type of protection and the conditions for control specific for the type of protection according to the EC type examination certificate.

1.2 Notes on possible personal injury

WARNING

Risk of personal injury due to moving parts on the valve.

During operation and when the solenoid valve is triggered, the valve moves through its entire travel range. Injury to hands or fingers is possible if they are inserted into the valve.

- While the valve moves, do not insert hands or fingers into the valve yoke and do not touch any moving valve parts.

Intrinsic safety rendered ineffective in intrinsically safe devices.

Every time the solenoid valve is operated, even not within the plant (e.g. during maintenance, calibration and work on equipment), it must be ensured that the conditions for intrinsically safe circuits are observed.

- Only connect intrinsically safe devices intended for use in intrinsically safe circuits to certified intrinsically safe input-connected units.
- Do not place intrinsically safe devices back into operation that were connected to intrinsically safe input-connected units without certification.
- Do not exceed the maximum permissible electric values specified in the EC type examination certificates when interconnecting intrinsically safe electrical equipment (U_i or U_0 , I_i or I_0 , P_i or P_0 , C_i or C_0 and L_i or L_0).

1.3 Notes on possible property damage

! NOTICE

Risk of damage to the solenoid valve due to incorrect mounting position.

- Do not mount the solenoid valve with the vent opening facing upward.
- Do not seal the vent opening when the device is installed on site.

Risk of damage to the solenoid valve due to impermissible pressures.

- Do not connect a supply pressure to the solenoid valve that exceeds the maximum supply pressure.

Incorrect assignment of the terminals will damage the solenoid valve and will lead to malfunction.

For the solenoid valve to function properly, the prescribed terminal assignment must be observed.

- Connect the electrical wiring to the solenoid valve according to the prescribed terminal assignment.

2 Markings on the device

2.1 Nameplate

Versions without explosion protection (example)

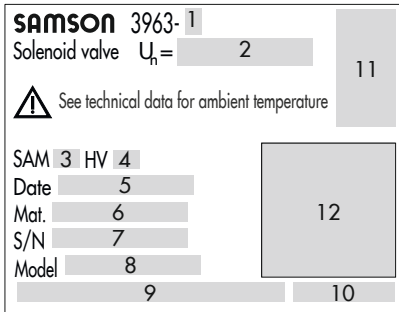

Versions with explosion protection (example)

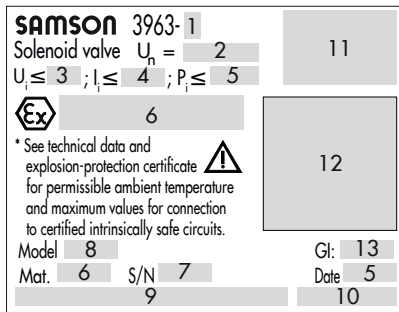

- | | | | |
|---|--|----|---|
| 1 | Configuration | 7 | Serial number |
| 2 | Nominal signal | 8 | Model number |
| 3 | Code for NAMUR Recommendation NE 53 (internal specification) | 9 | Production site |
| 4 | Hardware version | 10 | Product origin |
| 5 | Date of manufacture | 11 | Approvals (CE, EAC, UKCA etc.) |
| 6 | Material number | 12 | Data Matrix code (electronic nameplate) |

2.2 Article code

i Note

The "NAMUR interface according to VDI/VDE 3845" version in combination with K_{VS} 0.32 has an Ematal coating (Type 3963-xxxxx02xxxxxxxxxx).

Solenoid valve	Type 3963-	x	x	x	x	x	x	x	x	x	x	x	x	x	x	x	x	x
Type of protection																		
No explosion protection	0																	
ATEX ¹⁾ II 2G Ex ia IIC T6 Gb (max. 60/70/80 °C in T6/T5/T4)	1																	
CSA/FM Ex ia (max. 60/70/80 °C in T6/T5/T4)	3																	
ATEX ²⁾ II 3G Ex nA II T6 Gc/II 3G Ex ic IIC Gc (max. 60/70/80 °C in T6/T5/T4)	8																	
Nominal signal																		
6 V DC, 5.47 mW power consumption	1																	
12 V DC, 13.05 mW power consumption	2																	
24 V DC, 26.71 mW power consumption	3																	
230 V AC, 0.46 VA power consumption (without explosion protection)	5																	
115 V AC, 0.17 VA power consumption (without explosion protection)	6																	
Manual override																		
Without manual override SIL/TÜV	0																	
Pushbutton underneath the enclosure cover SIL/TÜV	1																	
External pushbutton (accessible using a pin)	2																	
External switch (accessible using a screwdriver)	3																	
Switching function																		
3/2-way function with spring-return mechanism SIL/TÜV (all K_{VS} coefficients)	0																	
5/2-way function with spring-return mechanism (K_{VS} 0.16, 1.4, 2.9, 4.3; SIL with K_{VS} 0.16)	1																	
5/2-way function with two detent positions TÜV (K_{VS} 1.4/2.9)	2																	
5/3-way function with spring-centered mid-position (ports 2 and 4 closed) (K_{VS} 1.4)	3																	
5/3-way function with spring-centered mid-position (ports 2 and 4 vented) TÜV (K_{VS} 1.4)	5																	

Markings on the device

Solenoid valve	Type 3963-	x	x	x	x	x	x	x	x	x	x	x	x	x	x	x	x	x
6/2-way function with spring-return mechanism (K _{V5} 0.16, 4.3; SIL with K _{V5} 0.16)	8																	
Restrictors																		
Without restrictors SIL/TÜV (all K _{V5} coefficients)	0																	
One exhaust air restrictor (3/2-way function/NAMUR interface or mounting block/K _{V5} 0.16)	1																	
Two exhaust air restrictors (5/2-way function/NAMUR interface/K _{V5} 0.16)	2																	
One supply air/exhaust air restrictor (3/2-way function/NAMUR interface/K _{V5} 0.16)	3																	
Attachment																		
NAMUR interface according to VDI/VDE 3845 SIL/TÜV (all K _{V5} coefficients) ⁹⁾	0																	
Threaded connection for rail, wall or pipe mounting SIL/TÜV (K _{V5} 0.16, 0.32, 1.4, 4.3)	1																	
NAMUR rib according to IEC 60534-6-1 SIL/TÜV (K _{V5} 0.32)	2																	
Mounting block for Type 3277 Linear Actuator SIL/TÜV (K _{V5} 0.16, 0.32)	3																	
Type 3963 (flange), only as spare part (K _{V5} 0.01/0.16)	4																	
K_{V5}³⁾																		
0.16 SIL/TÜV	1																	
0,32 SIL/TÜV ⁹⁾	2																	
1.4 TÜV	3																	
4.3 SIL/TÜV	4																	
0.01 (as spare part)	5																	
2.9 (NAMUR interface)	6																	
2.0 SIL/TÜV (NAMUR interface)	7																	
Pneumatic connection																		
G ¼ (K _{V5} 0.16, 0.32, 1.4, 2.0)	0																	
¼ NPT (K _{V5} 0.16, 0.32, 1.4, 2.0)	1																	
G ½ (K _{V5} 2.9, 4.3)	2																	
½ NPT (K _{V5} 2.9, 4.3)	3																	
Without (pilot valve as spare part/mounting block for Type 3277 Linear Actuator)	4																	
Pilot supply																		
Internal pilot supply for actuators for on/off service	0																	
External pilot supply for actuators for throttling service	1																	

Solenoid valve	Type 3963- x x x x x x x x x x x x x x									
Electrical connection										
Blanking plug M20x1.5	0	0								
M20x1.5 cable gland, black polyamide	0	1								
M20x1.5 cable gland, blue polyamide	1	1								
Adapter M20x1.5 to ½ NPT (aluminum)	1	2								
M20x1.5 cable gland (CEAG), black polyamide	1	3								
M20x1.5 cable gland, nickel-plated brass	1	4								
M20x1.5 cable gland, nickel-plated brass, blue	1	5								
M20x1.5 cable gland (CEAG), blue polyamide	1	6								
M20x1.5 cable gland (Jacob), blue polyamide	1	7								
Device connector according to DIN EN 175301-803, black polyamide ¹⁾	2	3								
Device connector with LED according to DIN EN 175301-803, black polyamide ¹⁾	2	5								
Adapter M20x1.5 to ½ NPT (stainless steel)	2	6								
Degree of protection										
IP 54 with polyethylene filter	0									
IP 65 with filter check valve made of polyamide	1									
IP 65 with filter check valve made of stainless steel	2									
NEMA 4 with filter check valve made of polyamide	4									
NEMA 4 with filter check valve made of stainless steel	5									
IP 65 with labyrinth-type vent plug	6									
Ambient temperature ⁵⁾										
-20 to +80 °C	0									
-45 to +80 °C	2									
Safety function										
Without	0									
SIL ⁶⁾	1									
TÜV ⁷⁾	2									
Special version ⁸⁾										
Without							0	0	0	
Material										
Connecting plate/booster valve enclosure made of 1.4404 on request							0	0	1	

Markings on the device

Solenoid valve		Type 3963- x x x x x x x x x x x x x x x												
Explosion protection														
CCC Ex	Ex ia IIC T4 ~ T6												0	0 9
EAC (GOST)	1Ex ia IIC T6...T4 Gb X												0	1 1
KCS	Ex ia IIC T6/T5/T4												0	1 3

1) EC type examination certificate PTB 01 ATEX 2085

2) Statement of conformity PTB 01 ATEX 2086 X

3) The air flow rate when $p_1 = 2.4$ bar and $p_2 = 1.0$ bar is calculated using the following formula: $Q = K_{VS} \times 36.22$ in m^3/h .

4) The cable socket is not included in the scope of delivery.

5) The permissible ambient temperature of the solenoid valve depends on the permissible ambient temperature of the components, type of protection and temperature class.

6) SIL according to IEC 61508

7) Emergency release or locking of compressed air supply

8) Further special versions on request

9) "NAMUR interface according to VDI/VDE 3845" version in combination with $K_{VS} 0.32$: with Ematal coating

3 Design and principle of operation

Solenoid valves actuated on one side

The solenoid valves consist of an electropneumatic binary converter (A) with (optional) manual override (B) and a booster valve (C) actuated on one side with return spring (Fig. 1).

The air supply for the electropneumatic binary converter (A) is routed internally through the booster valve (C) (delivered

state). The solenoid valve can be converted to accept an external pilot supply at port 9 by turning a gasket.

The pressure reducer (5) reduces the supply air pressure to 1.4 bar.

In the idle position, the flapper (2) is lifted off the outlet nozzle by the spring (3). As a result, a pressure lower than the deactivation pressure of the booster valve (C) builds up in the pressure divider, which consists of the restrictor (6) and outlet nozzle (1).

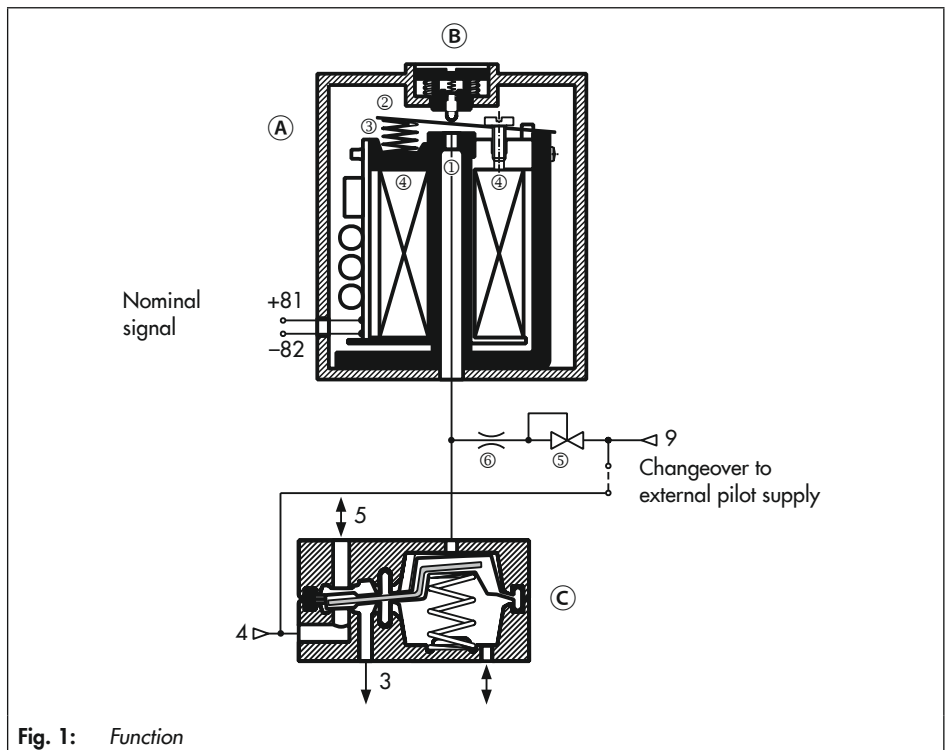

Fig. 1: Function

Design and principle of operation

When the solenoid coil ④ is energized by an electric binary signal, the outlet nozzle ① is closed by the flapper ② against the force of the spring ③. This causes the pressure in the pressure divider to rise above the activation pressure of the booster valve ⑤ and switches it to the operating position.

After the solenoid coil ④ is de-energized, the booster valve is switched to the neutral position again by a return spring.

Solenoid valves actuated on both sides

The solenoid valves consist of two electropneumatic binary converters ① with (optional) manual override ② and a booster valve ③ actuated on both sides with two detent positions or spring-centered mid-position.

The air supply for the electropneumatic binary converters ① is routed internally through the booster valve ③ (delivered state). The solenoid valve can be converted to accept an external pilot supply at port 9 by turning two gaskets.

The pressure reducer ④ reduces the supply air pressure to 1.4 bar.

In the idle position, the flapper ② is lifted off the outlet nozzle by the spring ③. As a result, a pressure lower than the deactivation pressure of the booster valve ③ builds up in the pressure divider, which consists of the restrictor ⑥ and outlet nozzle ①.

When the solenoid coil ④ is energized by an electric binary signal, the outlet nozzle ① is closed by the flapper ② against the force of the spring ③. This causes the pressure in the pressure divider to rise above the

activation pressure of the booster valve ③ and switches it to the operating position.

After the solenoid coil is de-energized, the operating position of the detented booster valve ③ is kept until the opposing signal is received. The spring-centered booster valve ③ is switched to the mid-position by a return spring after the solenoid coil is de-energized.

A simultaneous control of the electropneumatic binary converter ① must be ruled out on the electric control level.

3.1 Accessories

Accessories for Type 3963 Solenoid Valves	
Order no.	Designation
0790-6658	Cable socket according to EN 175301-803, form A, made of polyamide, black, degree of protection IP 65
1170-4069	Cable socket with LED according to EN 175301-803, form A, made of polyamide, black, degree of protection IP 65
1400-8298	Cable socket (Harting), 7-pole, made of aluminum, silver, degree of protection IP 65
8801-2810	Sensor connecting lead, two-wire, 3 m, blue, with angle connector M12x1, 4-pole, degree of protection IP 68
8831-0716	Cable socket (Binder), 7-pole, made of PBT GV, black, degree of protection IP 67
8831-0865	Cable socket M12x1, 4-pole, angled design, made of polyamide, black, degree of protection IP 67
3994-0160	Cable breakage protection with activation delay, enclosure for 35 mm rail mounting, IP 20 (for Type 3963-X1 with 6-V DC nominal signal)
1400-5268	Filter made of polyethylene, G 1/G ½ connection, degree of protection IP 54 (required for actuator size >1400 cm²)
8504-0066	Filter made of polyethylene, G ¼ connection, degree of protection IP 54
8504-0068	Filter made of polyethylene, G ½ connection, degree of protection IP 54
1790-7408	Filter check valve in housing with G ¼ thread made of polyamide, degree of protection IP 65
1790-7253	Filter check valve in housing with G ¼ thread made of 1.4301, degree of protection IP 65
1790-9645	Filter check valve in housing with G ¼ thread made of polyamide, degree of protection NEMA 4
1790-9646	Filter check valve in housing with G ¼ thread made of 1.4301, degree of protection NEMA 4
1400-5930	Mounting base for G-profile rail 32 according to EN 50035 (2 pcs. required)
1400-5931	Mounting base for 35 mm top-hat rail according to EN 50022 (2 pcs. required)
1400-6726	Mounting plate for wall mounting
1991-0451	Vent plug with G ¼ thread made of polyamide, degree of protection IP 65

Mounting kits for Type 3963 Solenoid Valves with threaded connections	
Order no.	Designation
1400-6759	Mounting kit for linear actuators (175 and 240 cm² actuator area, G ¼ connection) with pipe fitting, G ¼/G ¼ connection, made of CrNiMo steel
	Mounting kit for linear actuators (350, 355, 700 and 750 cm² actuator area, G ¾ connection)
1400-6735	with pipe fitting, G ½/G ¾ connection, made of CrNiMo steel
1400-6761	with pipe fitting, G ¼/G ¾ connection, made of CrNiMo steel
1400-6736	Mounting kit for linear actuators (1000 and 1400-60 cm² actuator area, G ¾ connection) with pipe fitting, G ½/G ¾ connection, made of CrNiMo steel
1400-6737	Mounting kit for linear actuators (1400-120, 1400-250, 2800 and 2 x 2800 cm² actuator area, G 1 connection) with pipe fitting, G ½/G 1 connection, made of CrNiMo steel

Design and principle of operation

Mounting kits for Type 3963 Solenoid Valves with threaded connections	
Order no.	Designation
1400-6749	Mounting kit for linear actuators (175/240 cm ² actuator area, G ¼ connection) with mounting bracket made of CrNiMo steel and screw fittings for 8x1 pipe, G ¼/G ¼ connection, made of zinc-plated steel
1400-6750	and screw fittings for 8x1 pipe, G ¼/G ¼ connection, made of CrNiMo steel
1400-6738	Mounting kit for linear actuators (350, 355, 700 and 750 cm ² actuator area, G ⅜ connection) with mounting bracket made of CrNiMo steel and screw fittings for 8x1 pipe, G ¼/G ⅜ connection, made of zinc-plated steel
1400-6739	and screw fittings for 8x1 pipe, G ¼/G ⅜ connection, made of CrNiMo steel
1400-6743	and screw fittings for 12x1 pipe, G ¼/G ⅜ connection, made of CrNiMo steel
1400-6744	and screw fittings for 10x1 pipe, G ¼/G ⅜ connection, made of polyamide
1400-6745	and screw fittings for 10x1 pipe, G ¼/G ⅜ connection, made of polyamide
1400-6740	Mounting kit for linear actuators (700/750 cm ² actuator area, G ⅜ connection) with mounting bracket made of CrNiMo steel and screw fittings for 12x1 pipe, G ½/G ⅜ connection, made of zinc-plated steel
1400-6741	and screw fittings for 12x1 pipe, G ¼/G ⅜ connection, made of zinc-plated steel
1400-6742	and screw fittings for 12x1 pipe, G ½/G ⅜ connection, made of CrNiMo steel

Mounting kits for Type 3963 Solenoid Valves with NAMUR interface	
Order no.	Designation
1400-6746	Mounting kit for linear actuators (350, 355, 700 and 750 cm ² actuator area, G ⅜ connection) with NAMUR rib using adapter plate for NAMUR rib/interface (order no. 1400-6751) and screw fittings for 12x1 pipe, G ¼/G ⅜ connection, made of zinc-plated steel
1400-6747	and screw fittings for 12x1 pipe, G ¼/G ⅜ connection, made of CrNiMo steel
1400-6748	and screw fittings for 10x1 pipe, G ¼/G ⅜ connection, made of polyamide
1400-6752	Mounting kit for linear actuators (175 and 240 cm ² actuator area, G ¼ connection) with NAMUR rib using adapter plate for NAMUR rib/interface (order no. 1400-6751) and screw fittings for 6x1 pipe, G ¼/G ¼ connection, made of zinc-plated steel
1400-6753	and screw fittings for 6x1 pipe, G ¼/G ¼ connection, made of CrNiMo steel
1400-6756	and screw fittings for 10x1 hose, G ¼/G ¼ connection, made of polyamide
1400-6754	Mounting kit for linear actuators (350, 355, 700 and 750 cm ² actuator area, G ⅜ connection) with NAMUR rib using adapter plate for NAMUR rib/interface (order no. 1400-6751) and screw fittings for 8x1 pipe, G ¼/G ⅜ connection, made of zinc-plated steel
1400-6755	and screw fittings for 8x1 pipe, G ¼/G ⅜ connection, made of CrNiMo steel
1400-6757	and screw fittings for 10x1 pipe, G ¼/G ⅜ connection, made of polyamide
1400-6759	Mounting kit for linear actuators (175 and 240 cm ² actuator area, G ¼ connection) with pipe fitting, G ¼/G ¼ connection, made of CrNiMo steel
1400-3001	Mounting kit for Type 3353 Angle Seat Valve with adapter plate for NAMUR interface made of 1.4301

Accessories for mounting kits	
Order no.	Designation
0320-1416	Support for NAMUR rib (required when a positioner or limit switch is additionally mounted to the linear actuator, DN 50)
8320-0131	M8x60 hex screw, A4, DIN 931
1400-6751	Adapter plate with NAMUR rib/NAMUR interface (G ¼)
1400-9924	Adapter plate with NAMUR rib/NAMUR interface with Ematal coating (¼ NPT)
	Mounting block for Type 3277 Linear Actuator with mounted Types 3793, 3766, 3767 and 3730 Positioners
1400-8813	G ¼ connection
1400-8814	¼ NPT connection
1400-6950	Pressure gauge mounting block, 1x Output and 1x Supply, made of stainless steel/brass (for mounting block)
	Piping for actuator with "stem retracts" fail-safe action
1400-6444	240 cm ² actuator area, zinc-plated steel
1400-6445	240 cm ² actuator area, CrNiMo steel
1400-6446	350 cm ² actuator area, zinc-plated steel
1400-6447	350 cm ² actuator area, CrNiMo steel
1400-6448	700 cm ² actuator area, zinc-plated steel
1400-6449	700 cm ² actuator area, CrNiMo steel

3.2 Technical data

General data		
Design	Solenoid with flapper/nozzle assembly and booster valve	
Degree of protection	IP 54 with filter	
	IP 65 with filter check valve	
Material	Enclosure	Polyamide PA 6-3-T-GF35, black
	Connecting plate	AlMg, powder coated, gray beige RAL 1019 or Ematal coating (depending on the version: see article code)
		1.4404 (see Chapter 2.2 for special versions)
		Polyamide PA 6-3-T-GF35, black
	Screws	1.4571
	Springs	1.4310
	Seals	Silicone rubber, Perbunan
	Diaphragms	Chloroprene rubber 57 Cr 868 (-20 to +80 °C)
Silicone rubber (-45 to +80 °C)		
Supply air	Medium	Instrument air free from corrosive substances or nitrogen
	Pressure	1.4 to 6 bar
Air consumption		≤80 l/h at 1.4 bar supply air in neutral position
		≤10 l/h at 1.4 bar pilot supply in operating position
Switching time		≤65 ms
Service life		≥2 × 10 ⁷ switching cycles (at -20 to +80 °C)
		≥2 × 10 ⁶ switching cycles (at -45 to +80 °C)
Ambient temperature		Refer to Electric data
Mounting orientation		Any

Electric data							
Type 3963		-X1	-X2	-X3	-06	-05	
Nominal signal	U_N	6 V DC Max. 27 V ¹⁾	12 V DC Max. 25 V ¹⁾	24 V DC Max. 32 V ¹⁾	115 V AC Max. 130 V ¹⁾	230 V AC Max. 255 V ¹⁾	
	f_N				48 to 62 Hz		
Switching point	ON	$U_{+80\text{ °C}}$	≥4.8 V	≥9.6 V	≥18 V	82 to 130 V	183 to 255 V
		$I_{+20\text{ °C}}$	≥ 1.41 mA	≥ 1.52 mA	≥ 1.57 mA	≥ 2.2 mA	≥ 2.6 mA
		$P_{+20\text{ °C}}$	≥5.47 mW	≥13.05 mW	≥26.71 mW	≥0.17 VA	≥0.46 VA
	OFF	$U_{-25\text{ °C}}$	≤1.0 V	≤2.4 V	≤4.7 V	≤18 V	≤36 V
Impedance	$R_{+20\text{ °C}}$	2.6 kΩ	5.5 kΩ	10.7 kΩ	Approx. 40 kΩ	Approx. 80 kΩ	
Effect of temperature		0.4 %/°C	0.2 %/°C	0.1 %/°C	0.05 %/°C	0.03 %/°C	
Type of protection Ex ia IIC ²⁾ for use in hazardous areas (Zone 1)							
Type 3963		-11	-12	-13			
Maximum values when connected to a certified intrinsically safe circuit							
Output voltage ⁴⁾	U_i	25 V · 27 V · 28 V · 30 V · 32 V					
Output current ⁴⁾	I_i	150 mA · 125 mA · 115 mA · 100 mA · 85 mA					
Power dissipation	P_i	250 mW	No restrictions				
Outer capacitance	C_i	≈0					
Outer inductance	L_i	≈0					
Ambient temperature in temperature class	T6	-45 to +60 °C					
	T5	-45 to +70 °C					
	T4	-45 to +80 °C					
Type of protection Ex nA II ³⁾ for use in hazardous areas (Zone 2)							
Type 3963		-81	-82	-83			
Ambient temperature in temperature class	T6	-45 to +60 °C					
	T5	-45 to +70 °C					
	T4	-45 to +80 °C					

1) Maximum permissible value at 100 % duty cycle. The maximum permissible value U_i applies to explosion-protected versions.

2) II 2G Ex ia IIC T6 according to EC type examination certificate PTB 01 ATEX 2085

3) II 3G Ex nA II T6 according to statement of conformity PTB 01 ATEX 2086 X

4) Pairs of values U_i/I_i apply to 6, 12, 24 V DC nominal signals.

Design and principle of operation

Solenoid valves actuated on one side, K_{VS} 0.16 or K_{VS} 0.32				
Switching function	3/2-way function	3/2-way function	5/2-way function	6/2-way function
K_{VS} ¹⁾	0.16	0.32	0.16	0.16
Safety function	SIL ³⁾ , TÜV ⁴⁾	SIL ³⁾ , TÜV ⁴⁾	SIL ³⁾ , TÜV ⁴⁾	–
Design	Diaphragm switching element, soft seated, with return spring			
Operating medium	Instrument air free from corrosive substances ⁵⁾ , air containing oil or non-corrosive gases ⁶⁾			
Operating pressure	Max. 6 bar			
Output signal	Operating pressure			
Ambient temperature ²⁾	–45 to +80 °C			
Connection	G 1/4 or 1/4 NPT			
Approx. weight	570 g (standard version)			

¹⁾ The air flow rate when $p_1 = 2.4$ bar and $p_2 = 1.0$ bar is calculated using the following formula: $Q = K_{VS} \times 36.22$ in m^3/h .

²⁾ The permissible ambient temperature of the solenoid valve depends on the permissible ambient temperature of the components, type of protection and temperature class.

³⁾ SIL according to IEC 61508

⁴⁾ Emergency release or locking of compressed air supply

⁵⁾ With internal pilot supply

⁶⁾ With external pilot supply

Solenoid valve, actuated on one side, K_{VS} 4.3, with threaded connections				
Switching function	3/2-way function	3/2-way function	5/2-way function ⁷⁾	6/2-way function ⁷⁾
K_{VS} ¹⁾ (direction of flow)	1.9 (4→3) 1.5 (3→4) 4.3 (3→5) 4.7 (5→3)	1.9 (4→3) 1.5 (3→4) 4.3 (3→5) 4.7 (5→3)	1.9 (4→3) 1.5 (3→4) 4.3 (3→5) 4.7 (5→3)	1.9 (4→3) 1.5 (3→4) 4.3 (3→5) 4.7 (5→3)
Ambient temperature ²⁾	-20 to +80 °C	-45 to +80 °C	-20 to +80 °C	-20 to +80 °C
Safety function	SIL ³⁾ , TÜV ⁴⁾	SIL ³⁾ , TÜV ⁴⁾	-	-
Design	Poppet valve with diaphragm actuator, soft seated, with return spring			
Material	Enclosure	Aluminum, powder coated, gray beige RAL 1019 1.4404 (see Chapter 2.2 for special versions)		
	Diaphragm	Chloroprene rubber	Silicone rubber	Chloroprene rubber
	Seals	Chloroprene rubber	Silicone rubber	Chloroprene rubber
	Screws	1.4571		
Actuation	Controlled on one side with a pilot valve, K_{VS} 0.16			
Operating medium	Instrument air free from corrosive substances or nitrogen ⁵⁾ Instrument air free from corrosive substances, air containing oil or non-corrosive gases ⁶⁾			
Max. operating pressure (direction of flow)	10 bar (4→3, 3→5) 2 bar (as required)	10 bar (4→3, 3→5) 2 bar (as required)	10 bar (as required) 2 bar (as required)	10 bar (as required) 2 bar (as required)
Switching cycles (operating pressure)	$\geq 10^7$ (6 bar) $\geq 10^6$ (10 bar)	$\geq 10^6$ (6 bar) $\geq 10^5$ (10 bar)	$\geq 10^7$ (6 bar) $\geq 10^6$ (10 bar)	$\geq 10^7$ (6 bar) $\geq 10^6$ (10 bar)
Connection	G 1/2 or 1/2 NPT			
Approx. weight	585 g (standard version)		1100 g (standard version)	

- 1) The air flow rate when $p_1 = 2.4$ bar and $p_2 = 1.0$ bar is calculated using the following formula: $Q = K_{VS} \times 36.22$ in m^3/h .
- 2) The permissible ambient temperature of the solenoid valve depends on the permissible ambient temperature of the components, type of protection and temperature class.
- 3) SIL according to IEC 61508
- 4) Emergency release or locking of compressed air supply
- 5) With internal pilot supply
- 6) With external pilot supply
- 7) Connecting hose between booster valves made of polyamide, see dimensional diagram on page 32 and dimensional diagram on page 33

Design and principle of operation

Solenoid valve, actuated on one side, K_{VS} 2.0 or 4.3, with NAMUR interface				
Switching function	3/2-way function with exhaust air feedback			
K_{VS} ¹⁾ (direction of flow)	1.1 (4→3) 2.0 (3→5)	1.1 (4→3) 2.0 (3→5)	1.9 (4→3) 4.3 (3→5)	1.9 (4→3) 4.3 (3→5)
Ambient temperature ²⁾	-20 to +80 °C	-45 to +80 °C	-20 to +80 °C	-45 to +80 °C
Safety function	SIL ³⁾ , TÜV ⁴⁾	SIL ³⁾ , TÜV ⁴⁾	SIL ³⁾ , TÜV ⁴⁾	SIL ³⁾ , TÜV ⁴⁾
Design	Poppet valve with diaphragm actuator, soft seated, with return spring			
Material	Enclosure	Aluminum, powder coated, gray beige RAL 1019 1.4404 (see Chapter 2.2 for special versions)		
	Diaphragm	Chloroprene rubber	Silicone rubber	Chloroprene rubber Silicone rubber
	Seals	Chloroprene rubber	Silicone rubber	Chloroprene rubber Silicone rubber
	Screws	1.4571		
Actuation	Controlled on one side with a pilot valve, K_{VS} 0.16			
Operating medium	Instrument air free from corrosive substances or nitrogen ⁵⁾ Instrument air free from corrosive substances, air containing oil or non-corrosive gases ⁶⁾			
Max. operating pressure	10 bar	10 bar	10 bar	10 bar
Switching cycles (operating pressure)	$\geq 10^7$ (6 bar) $\geq 10^6$ (10 bar)	$\geq 10^6$ (6 bar) $\geq 10^5$ (10 bar)	$\geq 10^7$ (6 bar) $\geq 10^6$ (10 bar)	$\geq 10^7$ (6 bar) $\geq 10^5$ (10 bar)
Connection	Supply air	G 1/4 or 1/4 NPT, NAMUR interface 1/4" ⁷⁾ , G 3/8		G 1/2 or 1/2 NPT, NAMUR interface 1/2" ⁷⁾
	Exhaust air	G 1/2 or 1/2 NPT, NAMUR interface 1/2" ⁷⁾ , G 3/8		G 1/2 or 1/2 NPT, NAMUR interface 1/2" ⁷⁾
Approx. weight	1380 g (standard version)		1500 g (standard version)	

¹⁾ The air flow rate when $p_1 = 2.4$ bar and $p_2 = 1.0$ bar is calculated using the following formula: $Q = K_{VS} \times 36.22$ in m^3/h .

²⁾ The permissible ambient temperature of the solenoid valve depends on the permissible ambient temperature of the components, type of protection and temperature class.

³⁾ SIL according to IEC 61508

⁴⁾ Emergency release or locking of compressed air supply

⁵⁾ With internal pilot supply

⁶⁾ With external pilot supply

⁷⁾ NAMUR interface according to VDI/VDE 3845

Solenoid valves actuated on one side, K_{VS} 1.4 or K_{VS} 2.9		
Switching function		3/2-way function with exhaust air feedback
		5/2-way function
K_{VS} ¹⁾		1.4 or 2.9
Safety function		TÜV ²⁾ (with K_{VS} 1.4)
		–
Design		Spool, metal-to-metal seat, zero overlap, with return spring
Material	Enclosure	Aluminum, powder coated, gray beige RAL 1019 1.4404 (see Chapter 2.2 for special versions)
	Seals	Silicone
	Filter	Polyethylene
	Screws	1.4571
Actuation		Controlled on one side with a pilot valve, K_{VS} 0.01 (with 1.4) or K_{VS} 0.16 (with 2.9)
Operating medium		Instrument air free from corrosive substances or nitrogen ³⁾ Instrument air free from corrosive substances, air containing oil or non-corrosive gases ⁴⁾
Max. operating pressure		6 bar ³⁾ or 10 bar ⁴⁾
Ambient temperature ⁵⁾		–45 to +80 °C
Switching cycles		$\geq 2 \times 10^7$
Connection	K_{VS} 1.4	G ¼ or ¼ NPT, NAMUR interface ⁶⁾
	K_{VS} 2.9	G ½ or ½ NPT, NAMUR interface ⁶⁾
Approx. weight	K_{VS} 1.4	485 g (standard version)
	K_{VS} 2.9	1760 g (standard version)

- 1) The air flow rate when $p_1 = 2.4$ bar and $p_2 = 1.0$ bar is calculated using the following formula: $Q = K_{VS} \times 36.22$ in m^3/h .
- 2) Emergency release or locking of compressed air supply
- 3) With internal pilot supply
- 4) With external pilot supply
- 5) The permissible ambient temperature of the solenoid valve depends on the permissible ambient temperature of the components, type of protection and temperature class.
- 6) NAMUR interface according to VDI/VDE 3845

Design and principle of operation

Solenoid valves actuated on both sides, K_{VS} 1.4 or K_{VS} 2.9			
Switching function	5/2-way function with two detent positions	5/3-way function with spring-centered mid-position (ports 2 and 4 closed)	5/3-way function with spring-centered mid-position (ports 2 and 4 vented)
K_{VS} ¹⁾	1.4 or 2.9	1.4 (2.9 on request)	1.4 (2.9 on request)
Safety function	TÜV ²⁾ (with K_{VS} 1.4)	–	TÜV ²⁾ (with K_{VS} 1.4)
Design	Spool, metal-to-metal seat, zero overlap		
Material	Enclosure	Aluminum, powder coated, gray beige RAL 1019 1.4404 (see Chapter 2.2 for special versions)	
	Seals	Silicone	
	Filter	Polyethylene	
	Screws	1.4571	
Actuation	Controlled on both sides with two pilot valves, K_{VS} 0.01 (with 1.4) or K_{VS} 0.16 (with 2.9)		
Operating medium	Instrument air free from corrosive substances or nitrogen ³⁾ Instrument air free from corrosive substances, air containing oil or non-corrosive gases ⁴⁾		
Max. operating pressure	6 bar ³⁾ or 10 bar ⁴⁾		
Ambient temperature ⁵⁾	–45 to +80 °C		
Switching cycles	$\geq 2 \times 10^7$		
Connection	K_{VS} 1.4	G 1/4 or 1/4 NPT, NAMUR interface ⁶⁾	
	K_{VS} 2.9	G 1/2 or 1/2 NPT, NAMUR interface ⁶⁾	
Approx. weight	K_{VS} 1.4	685 g (standard version)	
	K_{VS} 2.9	2180 g (standard version)	

1) The air flow rate when $p_1 = 2.4$ bar and $p_2 = 1.0$ bar is calculated using the following formula: $Q = K_{VS} \times 36.22$ in m^3/h .

2) Emergency release or locking of compressed air supply

3) With internal pilot supply

4) With external pilot supply

5) The permissible ambient temperature of the solenoid valve depends on the permissible ambient temperature of the components, type of protection and temperature class.

6) NAMUR interface according to VDI/VDE 3845

Table 1: Summary of explosion protection approvals

Type 3963	Certification		Type of protection
-1	ATEX	Number PTB 01 ATEX 2085 Date 2019-11-18	II 2G Ex ia IIC T6...T4 Gb
	CCC Ex	Number 021322307003631 Date 2021-01-08 Valid until 2026-01-07	Ex ia IIC T4 ~ T6
	EAC (GOST)	Number RU C-DE.HA65.B.00806/20 Date 2020-11-10 Valid until 2025-05-11	1Ex ia IIC T6...T4 Gb X
	KCS	Number 13-KB4BO-0039 Date 2013-01-31 Valid until 2026-01-31	Ex ia IIC T6/T5/T4
	NEPSI	Number GYJ23.1086X Date 2023-04-29 Valid until 2028-04-28	Ex ia IIC T4...T6 Gb
	TR CMU 1055	Number ZETC/027/2024 Date 2021-08-25 Valid until 2024-08-24	Module D
-3	CSA	Number 1607857 Date 2021-11-30	Ex ia IIC T6: Class I, Zone 0; Class I, II, Div. 1, Groups A, B, C, D, E, F, G; Class I, II, Div. 2, Groups A, B, C, D, E, F, G
	FM	Number FM24US0232 Date 2025-01-02	IS Class I,II,III, Div.1, GP A,B,C,D,E,F,G, T* Type 4X IS Class I, Zn 0, AEx ia IIC, T* NI Class I, Div.2, GP A,B,C,D,F,G T*
-8	ATEX	Number PTB 01 ATEX 2086 X Date 2014-04-17	II 3G Ex nA II T6 Gc II 3G Ex ic IIC T6 Gc
	TR CMU 1055	Number ZETC/027/2024 Date 2024-04-22 Valid until 2027-08-24	Module D

3.3 Dimensions in mm

Solenoid valves without threaded connections

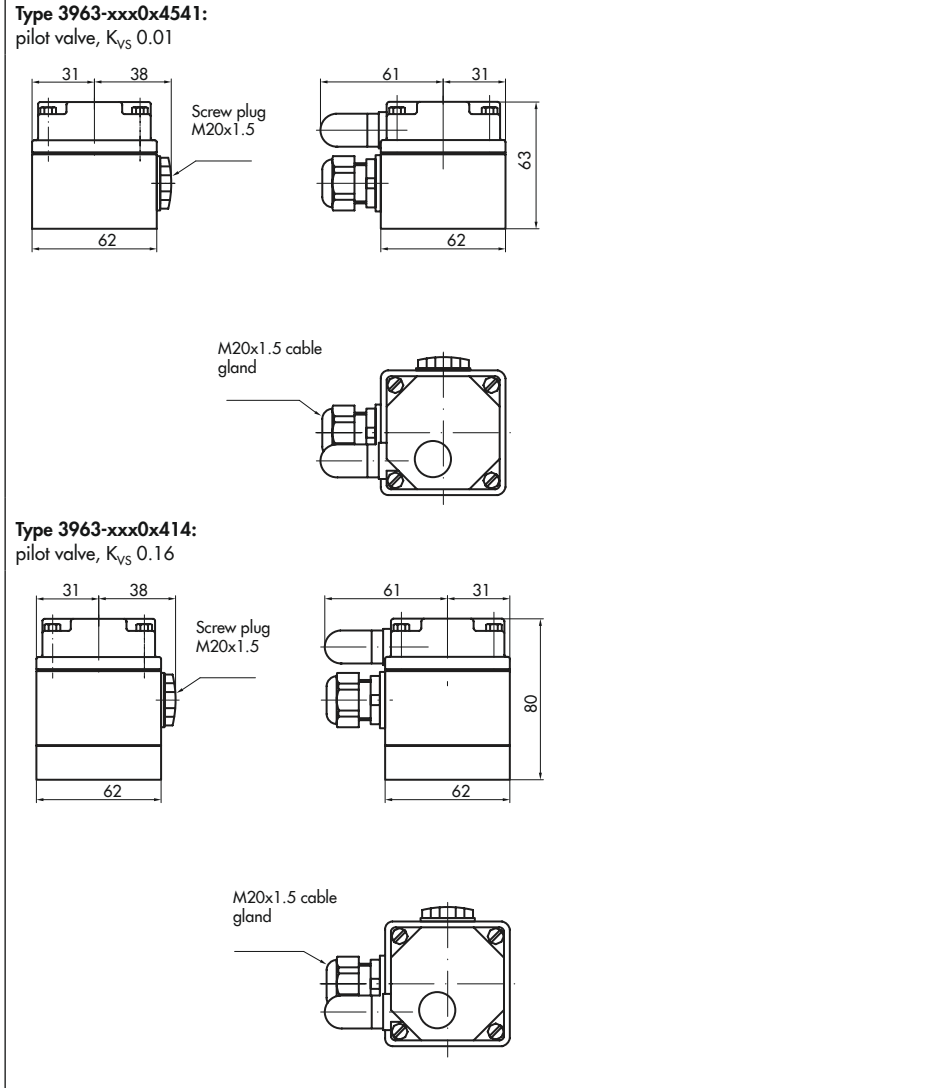

Solenoid valves with threaded connections

Type 3963-xxx1x11:

5/2-way solenoid valve, actuated on one side, K_{VS} 0.16

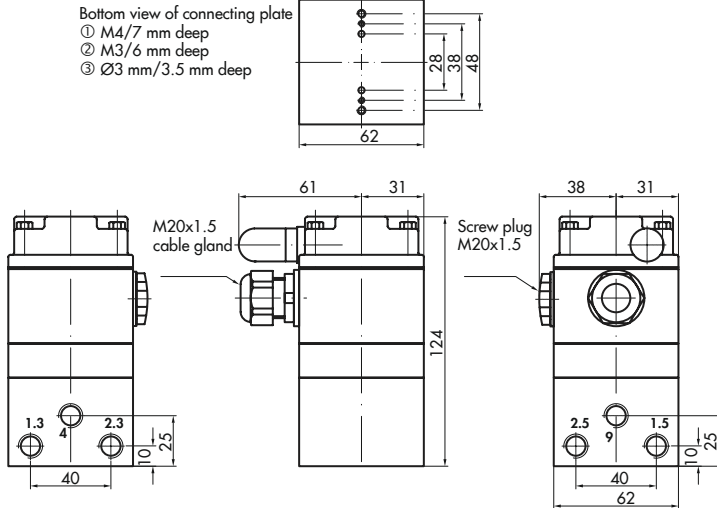

Type 3963-xxx0x11/ -xxx0x12:

5/2-way solenoid valve, actuated on one side, K_{VS} 0.16 or 3.2

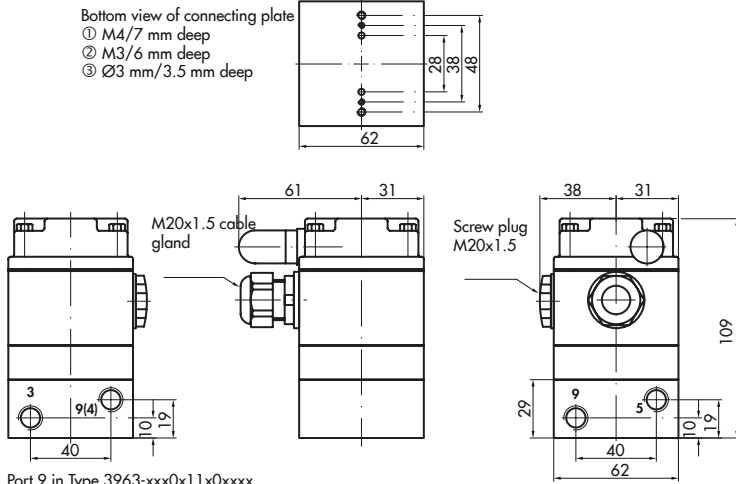

Port 9 in Type 3963-xxx0x11x0xxxx
Port 4 in Type 3963-xxx0x12xxxxxx

Ports 9 and 5 in Type 3963-xxx0x12xxxxxx

Design and principle of operation

Type 3963-xxx8x11:

6/2-way solenoid valve, actuated on one side, K_{VS} 0.16

Bottom view of connecting plate

- ① M4/7 mm deep
- ② M3/6 mm deep
- ③ Ø3 mm/3.5 mm deep

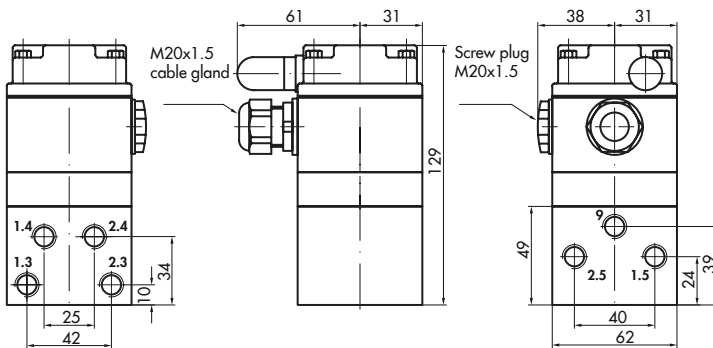
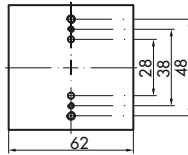

Types 3963-xxx0x314/-xxx0x324:

3/2-way solenoid valve, actuated on one side, K_{VS} 0.16 or 0.32, for mounting to linear actuators using a mounting block

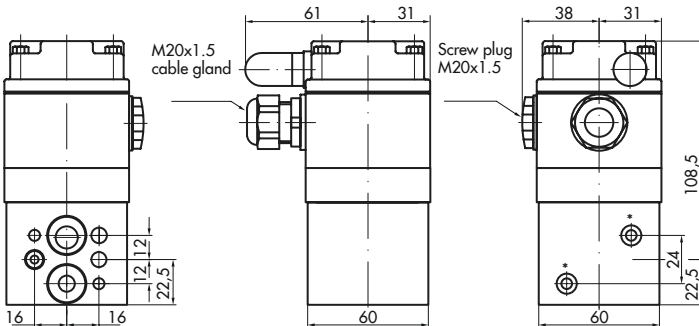

* Mounting to a mounting block using two M5x60 (DIN 912) screws

Type 3963-xxx0x14:

3/2-way solenoid valve, actuated on one side, K_{Vs} 4.3

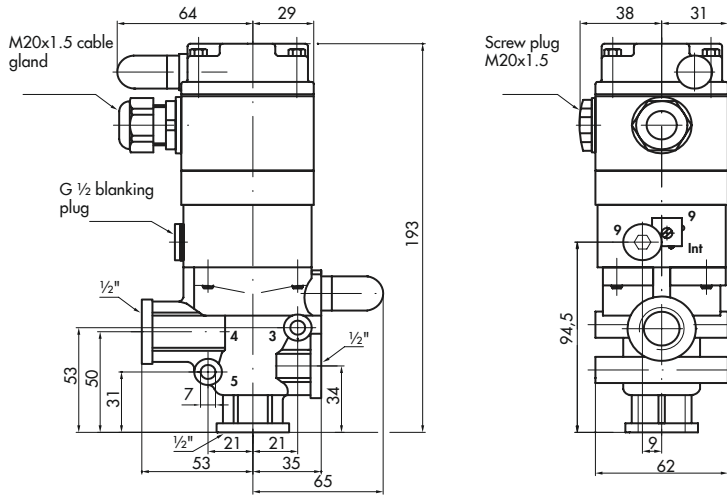

Design and principle of operation

Type 3963-xxx1x14:

5/2-way solenoid valve, actuated on one side, K_{VS} 4.3

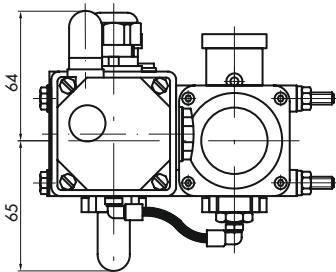
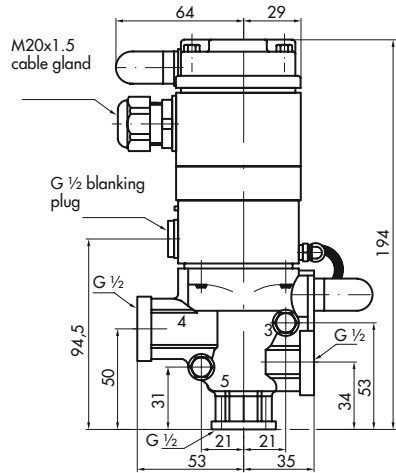
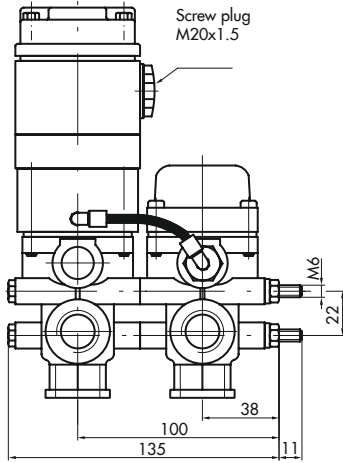

Type 3963-xxx1x14:

5/2-way solenoid valve, actuated on one side, K_{VS} 4.3

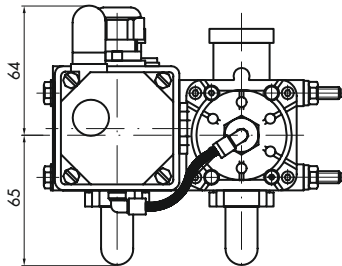
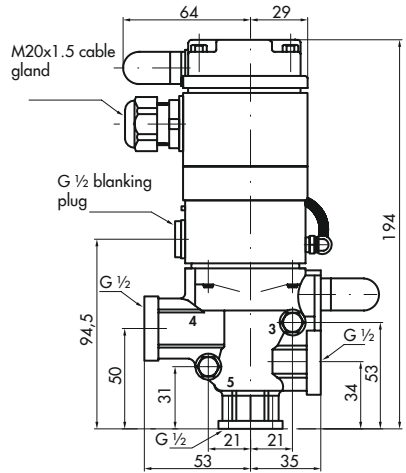
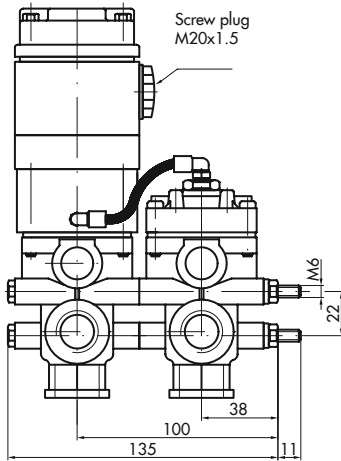

Design and principle of operation

Types 3963-xxx0x13/-xxx1x13:

3/2-way or 5/2-way solenoid valve, actuated on one side, K_{VS} 1.4

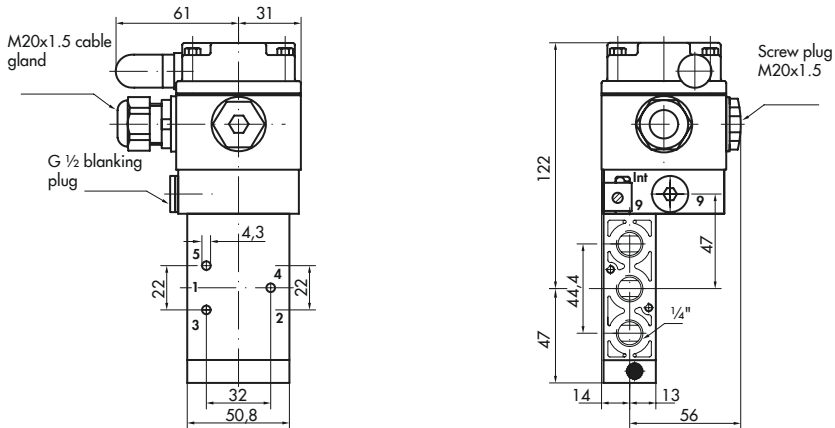

Port 5 is sealed when the 3/2-way function is used

Types 3963-xxx2x13/-xxx3x13/-xxx5x13:

5/2-way or 5/3-way solenoid valve, actuated on both sides, K_{VS} 1.4

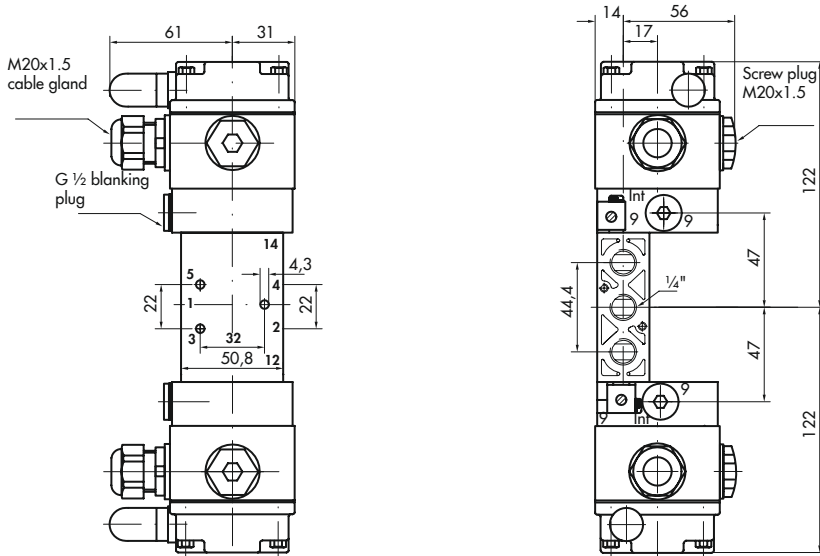

Solenoid valves with threaded connections for linear actuators with NAMUR rib

Type 3963-xxx0x22:

3/2-way solenoid valve, actuated on one side, K_{VS} 0.32

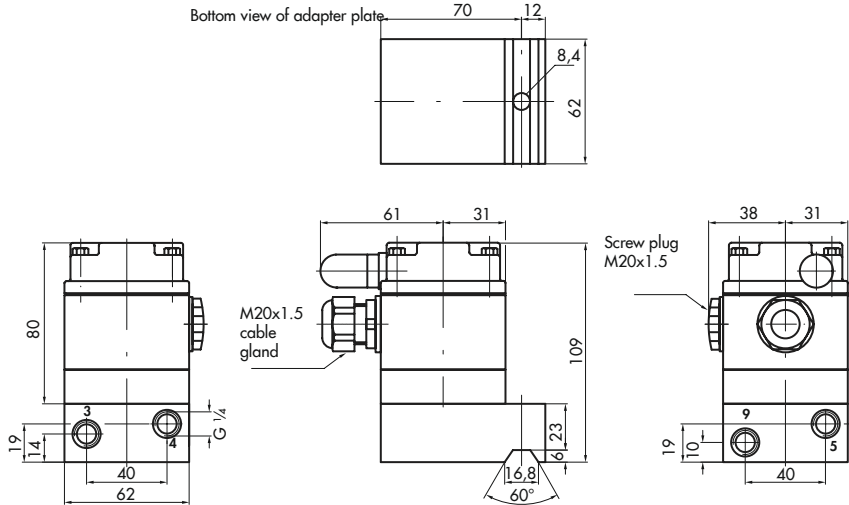

Types 3963-xxx0x01/-xxx1x01:

3/2-way or 5/2-way solenoid valve, actuated on one side, K_{VS} 0.16

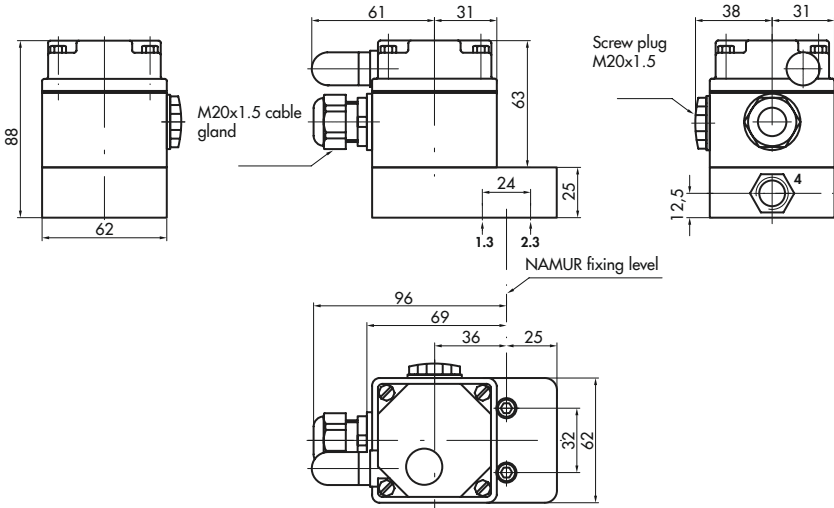

Design and principle of operation

Type 3963-xxx0x02:

3/2-way solenoid valve, actuated on one side, K_{VS} 0.32

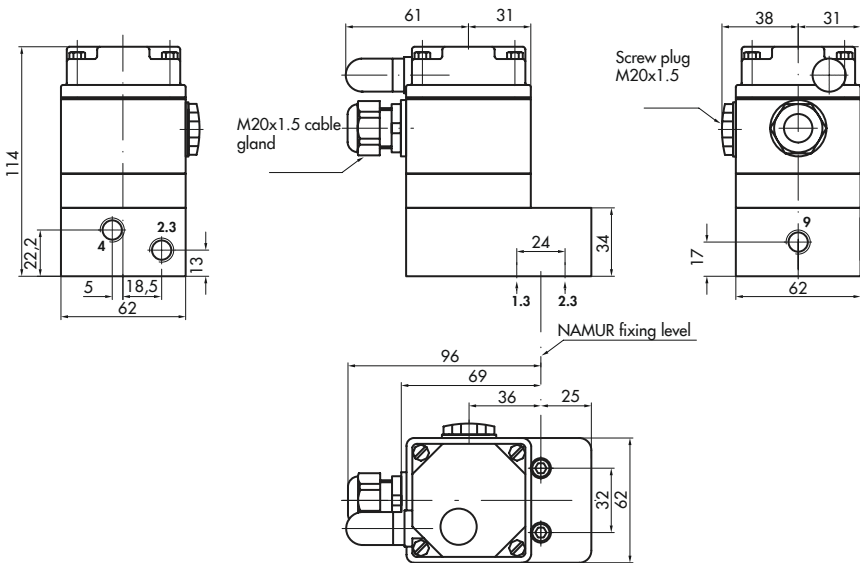

Solenoid valves with NAMUR interface for rotary actuators

Type 3963-xxx8x01:

6/2-way solenoid valve, actuated on one side, K_{VS} 0.16

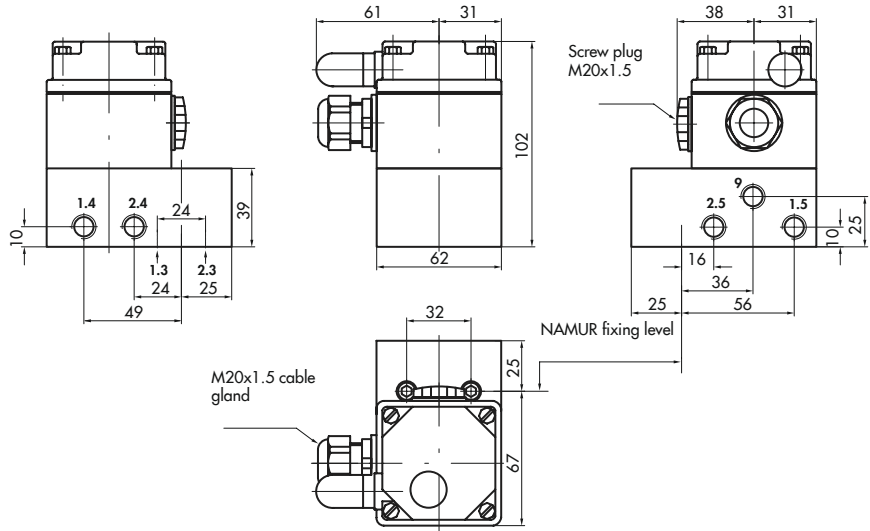

Types 3963-xxx0x03/-xxx1x03:

3/2-way or 5/2-way solenoid valve, actuated on one side, K_{VS} 1.4

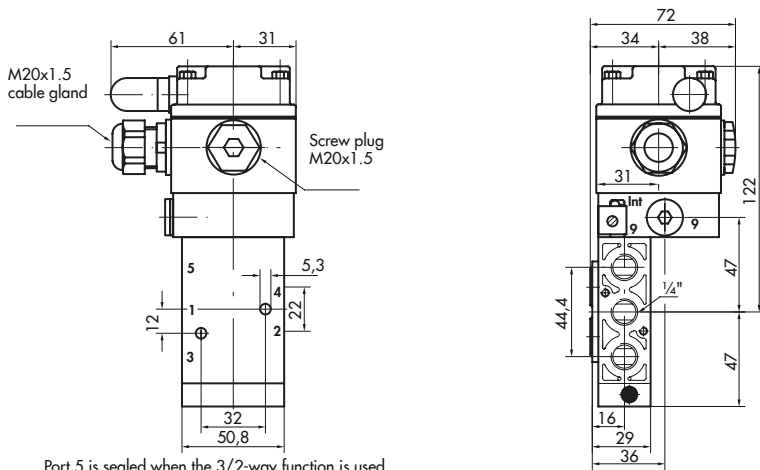

Design and principle of operation

Type 3963-xxx0x07:

3/2-way solenoid valve, actuated on one side, K_{VS} 2.0

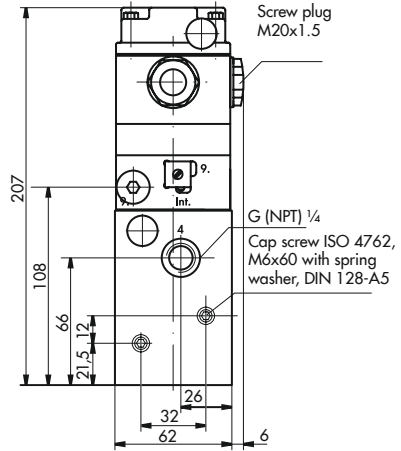
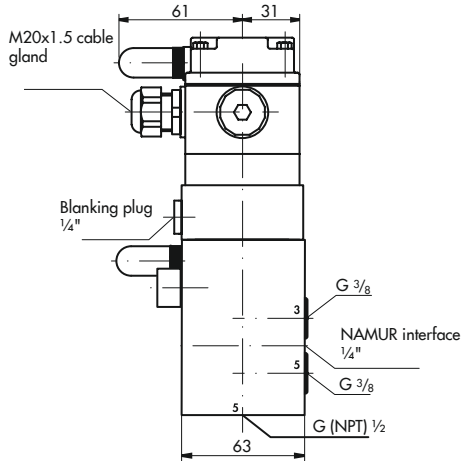

Type 3963-xxx0x04:

3/2-way solenoid valve, actuated on one side, K_{VS} 4.3

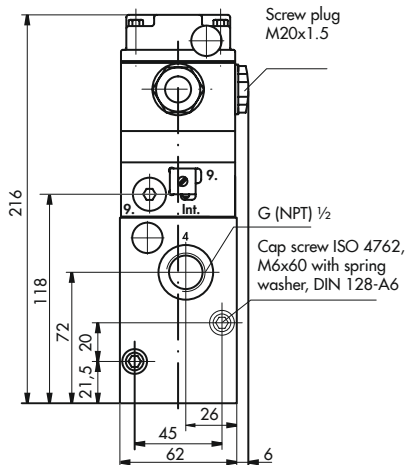
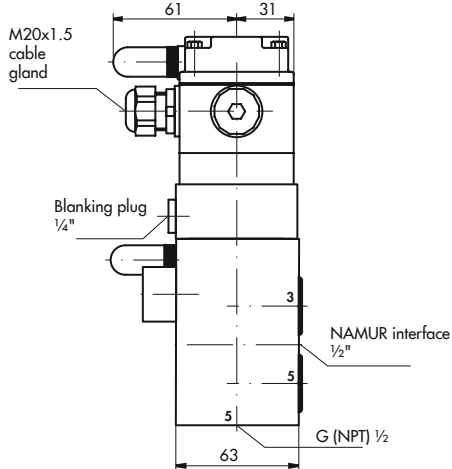

Type 3963-xxx1x06:

5/2-way solenoid valve, actuated on one side, K_{VS} 2.9

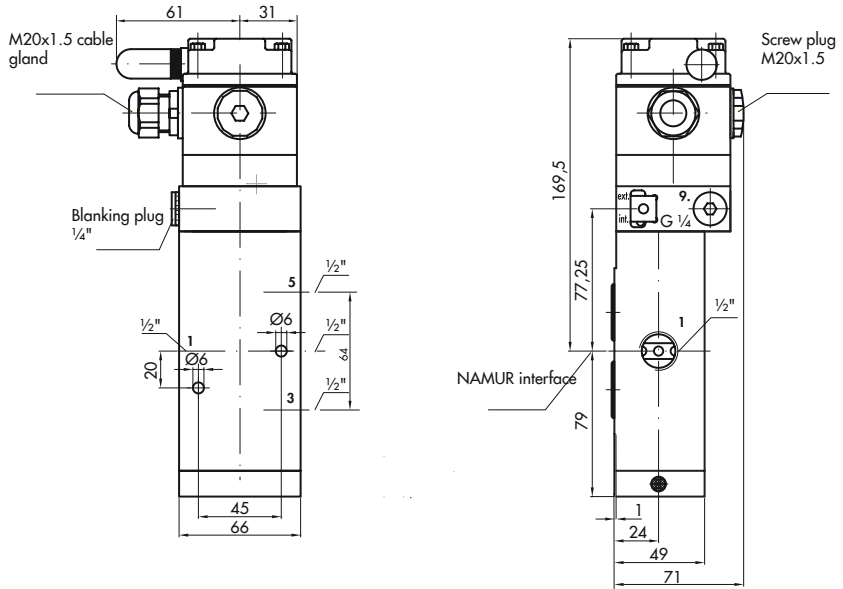

Design and principle of operation

Types 3963-xxx2x03/-xxx3x03/-xxx5x05:

5/2-way or 5/3-way solenoid valve, actuated on both sides, K_{VS} 1.4

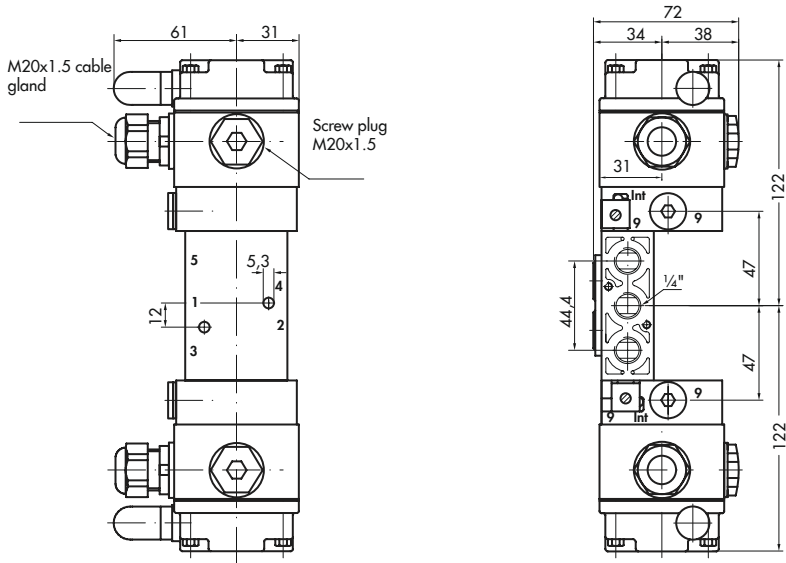

Type 3963-xxx2x06:

5/2-way solenoid valve, actuated on both sides, K_{VS} 2.9

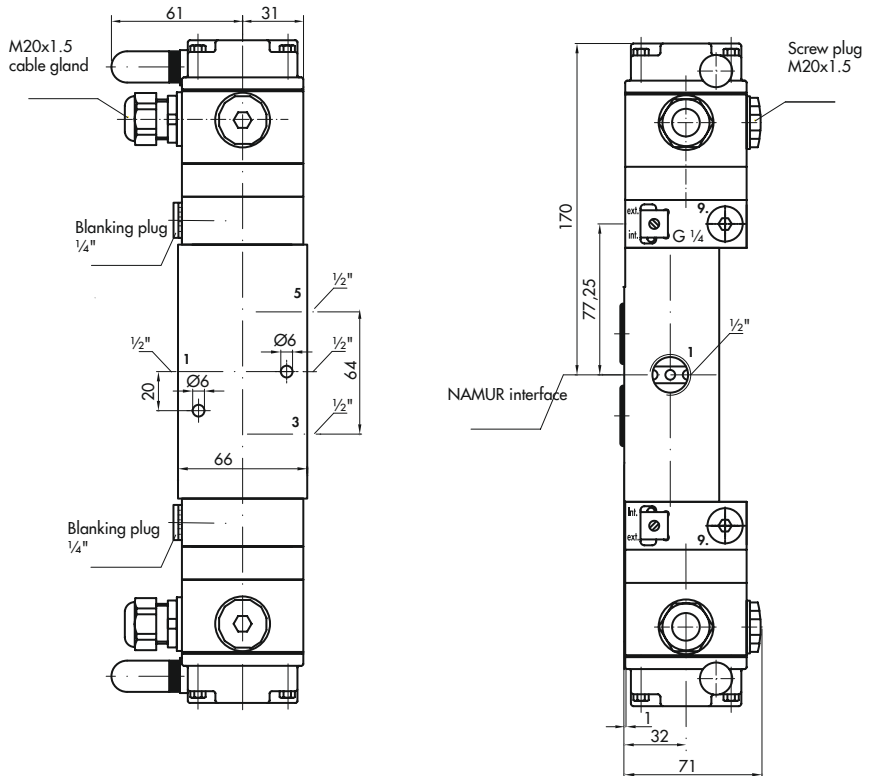

4 Measures for preparation

After receiving the shipment, proceed as follows:

1. Check the scope of delivery. Compare the shipment received with the delivery note.
2. Check the shipment for transportation damage. Report any damage to SAMSON and the forwarding agent (refer to delivery note).

4.1 Unpacking

NOTICE

Risk of solenoid valve damage due to foreign particles entering the valve.

- *Do not remove the packaging if the solenoid valve is to be transported to another location or kept in storage.*
 - *Do not remove the protective film/ protective caps until immediately before mounting the device on the valve.*
-

Before mounting the solenoid valve, proceed as follows:

1. Remove the packaging from the solenoid valve.
2. Dispose of the packaging in accordance with the valid regulations.

4.2 Storage

NOTICE

Risk of solenoid valve damage due to improper storage.

- *Observe the storage instructions. Contact SAMSON, if need be.*
-

Storage instructions

- Protect the solenoid valve against external influences (e.g. impact, shocks, vibration).
- Do not damage the corrosion protection (coating).
- Protect the solenoid valve against moisture and dirt. In damp spaces, prevent condensation. If necessary, use a drying agent or heating.
- Observe storage temperature depending on the permissible ambient temperature (see technical data in Chapter 3.2).
- Store solenoid valve with closed cover in airtight packaging.

5 Mounting and start-up

NOTICE

Risk of malfunction due to incorrectly performed start-up.

- *Perform start-up following the described sequence.*
-

The procedures to mount, install and start up the solenoid valve are described in the following. They must be performed in the prescribed sequence.

1. **Remove the protective caps from the pneumatic connections.**
2. **Mount the solenoid valve.**
→ Chapter 5.1 onward
3. **Perform pneumatic installation.**
→ Chapter 5.2 onward
4. **Perform electrical installation.**
→ Chapter 5.3 onward

5.1 Mounting

⚠ WARNING

Risk of personal injury due to parts bursting or the process medium spurting out under high pressure.

→ Before installation, depressurize the relevant plant section.

ℹ NOTICE

Risk of degree of protection being rendered ineffective.

→ Only operate the device with the enclosure cover mounted and the exhaust air filters installed.

Installation conditions

- Any mounting position may be used.

- The filter in the enclosure cover and the cable gland must face downward or, in cases where this is not possible, mount them in the horizontal position.
- On mounting, make sure that 300 mm or more clearance is kept above the enclosure cover.
- In cases where mechanical damage of the enclosure cannot be ruled out at the site of installation, mount additional protection to the enclosure.

5.1.1 Rail mounting

Types 3963-XXXXX11/-XXXXX12

Accessories	Order no.
Mounting base for G-profile rail 32	1400-5930
Mounting base for 35 mm top-hat rail	1400-5931

- Mount the solenoid valve on two mounting bases for G-profile rail 32 according to EN 50035 or 35 mm top-hat rail according to EN 50022.

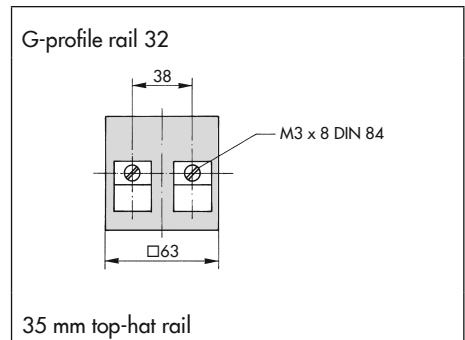

Mounting and start-up

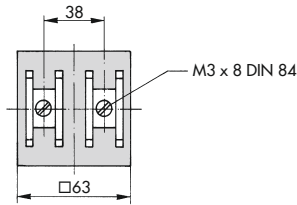

Fig. 2: Rail mounting

5.1.2 Wall mounting

Types 3963-XXXXX11/-XXXXX12

Accessories	Order no.
Mounting plate	1400-6726

→ Mount the solenoid valve on the mounting plate for wall mounting.

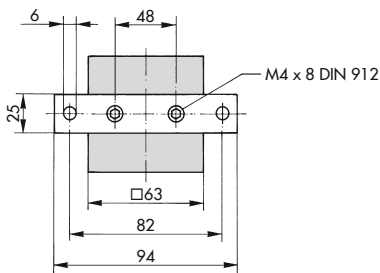

Fig. 3: Wall mounting

Types 3963-XXXXX13/-XXXXX14

→ Insert the screws through the boreholes and fasten the solenoid valve (see dimensions of the solenoid valve in Chapter 3.3.

5.1.3 Mounting on rotary actuators with NAMUR interface

Type 3963-XXXXX0X

The screws required for mounting are included in the scope of delivery.

- Before mounting the solenoid valve, check that two O-rings are seated properly.
- Determine the direction of action of the rotary actuator at the connecting flange with an M5x10 coded grub screw according to DIN 916.
- Mount the solenoid valve directly to the rotary actuator using two M5x35 (ISO 4762) screws.

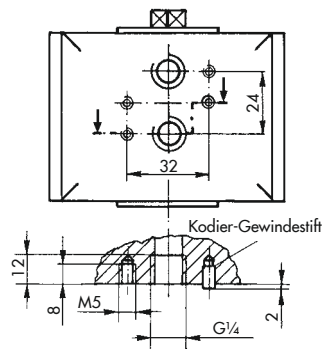
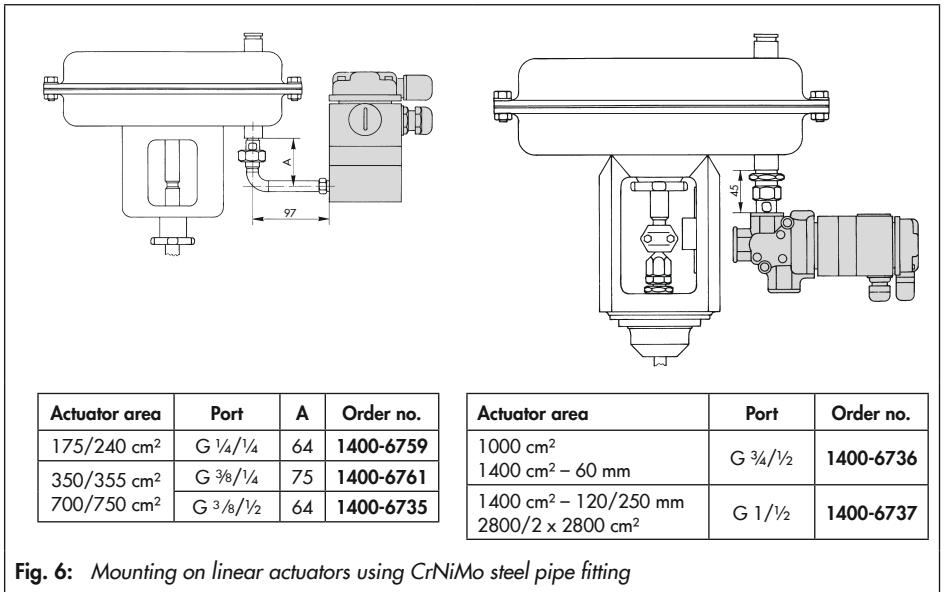
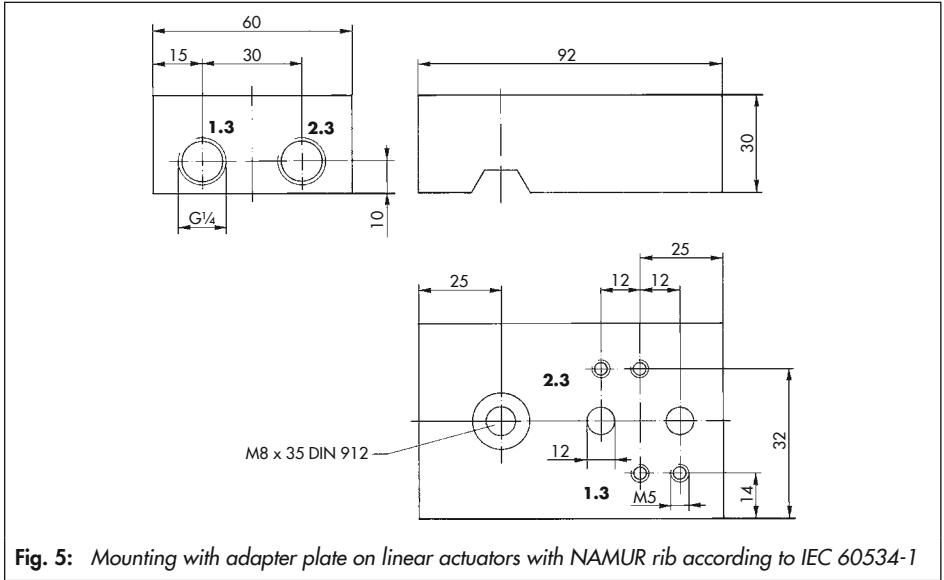

Fig. 4: Mounting on rotary actuators with NAMUR interface



5.1.4 Mounting to linear actuators with NAMUR rib

Type 3963-XXX002

- Fasten the solenoid valve using the M8x35 (ISO 4762) screws included in the scope of delivery.

Type 3963-XXX0X0

- Mount the solenoid valves to linear actuators using the adapter plate (Fig. 5).

When positioners or limit switches are also to be mounted to the linear actuator (DN 50 and smaller), a support (0320-1416) is required.

5.1.5 Mounting on linear actuators using CrNiMo steel pipe fitting

Type 3963-xxxxx11 (except for Types 3963xxx1011/-xxx8011)

Mounting on Type 3271 or 3277 Actuators according to Fig. 6 and the actuator mounting and operating instructions:

- ▶ EB 8310-X

5.1.6 Mounting on mounting block for SAMSON Type 3277 Pneumatic Actuator

Type 3963-XXXXX3X

The Types 3963-XXXXX3X Solenoid Valves are suitable for the simultaneous mounting of a Type 3730-X, 3731-X, 3766, 3767, 378X or 3793 Positioner to Type 3277 Linear Actuators (Fig. 7).

The screws required for mounting are included in the scope of delivery.

- Before mounting, check that the four O-rings are seated properly on the mounting surface.
- Mount the solenoid valve using two M5x55 (ISO 4762) screws.
- Read the actuator and positioner mounting instructions.

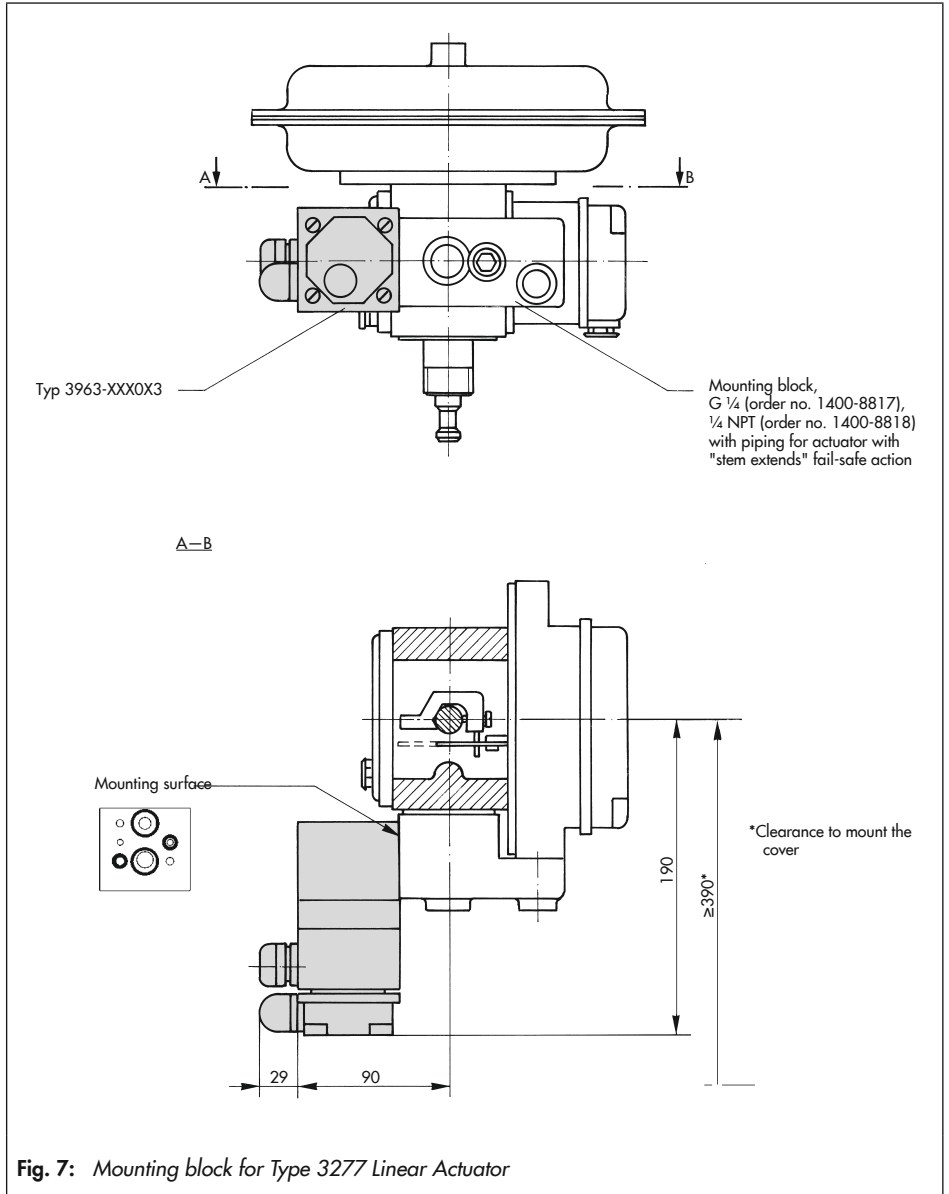

5.2 Pneumatic connection

⚠ WARNING

Risk of injury due to high pressure inside device.

→ Prior to performing repair and maintenance work on the device, depressurize the connecting lines.

The air connections are designed as threaded holes with G or NPT thread depending on the device version.

- Run and attach the connecting lines and screw joints according to good professional practice.
- Check the connecting lines and screw joints for leaks and damage at regular intervals and repair them, if necessary.
- The K_{VS} coefficient of an upstream pressure reducing valve must be at least 1.6 times larger than the K_{VS} coefficient of the solenoid valve.
- Protect the exhaust air connections by installing a filter or taking other appropriate precautions to prevent water or dirt from entering them.

5.2.1 Sizing of the connecting line

→ Refer to the table on page 48 for the minimum required nominal size of the connecting line.

The specifications apply to a connecting line shorter than 2 m. Use a larger nominal size for lines longer than 2 m.

Valve size (connection length ≤ 2 m)				
K_{VS} coefficient	0.16 0.32	1.4	2.0 4.3	—
Connection Pressure	4	1 and 3	4	9
≥ 1.4 bar	≥ DN 6	≥ DN 8	≥ DN 10	≥ DN 4
≥ 2.5 bar	≥ DN 4	≥ DN 6	≥ DN 8	
≥ 6 bar		≥ DN 4	≥ DN 6	

Types 3963-XXXX0X3/-XXXX014

Check whether the nominal size of the connecting line for these devices is sufficiently sized as follows:

1. Unscrew the threaded stopper from port 9 and mount a pressure gauge.
2. The nominal size of the connecting line is sufficient when the pressure reaches 1.3 bar or more during a switching process.

5.2.2 Compressed air quality

⚠ DANGER

Risk of asphyxiation due to the displacement of air when using nitrogen in unventilated spaces.

→ Discharge the exhaust air of the solenoid pilot valve and poppet valve over a common pipe to the atmosphere.

ⓘ NOTICE

An operating pressure above the maximum permissible operating pressure will damage the solenoid valve.

→ Observe the max. operating pressure (see technical data in Chapter 3.2).

→ If necessary, use a pressure reducer to restrict the operating pressure.

ⓘ NOTICE

Risk of malfunction due to failure to comply with air quality requirements.

→ Only use supply air that is dry and free of oil and dust.

→ Read the maintenance instructions for upstream pressure reducing stations.

→ Blow through all air pipes and hoses thoroughly before connecting them.

Operating medium for the booster valve

With internal pilot supply:

- Instrument air free from corrosive substances or nitrogen
- Operating pressure 1.4 to 6 bar

With external pilot supply over port 4 and K_{VS} 1.4 or 4.3:

- Instrument air free from corrosive substances, air containing oil or non-corrosive gases
- Operating pressure 0 to 10 bar

With external pilot supply over port 9

- Instrument air free from corrosive substances, air containing oil or non-corrosive gases
- Operating pressure 0 to 6 bar

Mounting and start-up

Supply air for the pilot valve

- Instrument air free from corrosive substances or nitrogen
- Operating pressure 1.4 to 6 bar

Compressed air quality according to ISO 8573-1		
Particle size and quantity	Oil content	Pressure dew point
Class 4	Class 3	Class 3
$\leq 5 \mu\text{m}$ and $1000/\text{m}^3$	$\leq 1 \text{ mg}/\text{m}^3$	$-20 \text{ }^\circ\text{C}/10 \text{ K}$ below the lowest ambient temperature to be expected

5.3 Changeover to external pilot supply over port 9

If the solenoid valve is to be used to switch the output signal (0 to 6 bar) of a positioner, the supply air must be routed externally over port 9.

Types 3963-XXXX0X4/-XXXXXX7

The supply air in these solenoid valves is fed internally over port 4, if not specified otherwise. To change to an external supply over port 9, proceed as follows:

1. Undo the cap screw on the connection plate and remove plate ① and gasket ②.
2. Turn the gasket ② 90°. The tip of gasket ② must rest in the plate cut-out marked '9'.
3. Fasten the plate ① and gasket ② to the connection plate.

i Note

The gasket of these solenoid valves must be inserted as specified for "Internal pilot supply at port 4" (see Fig. 10).

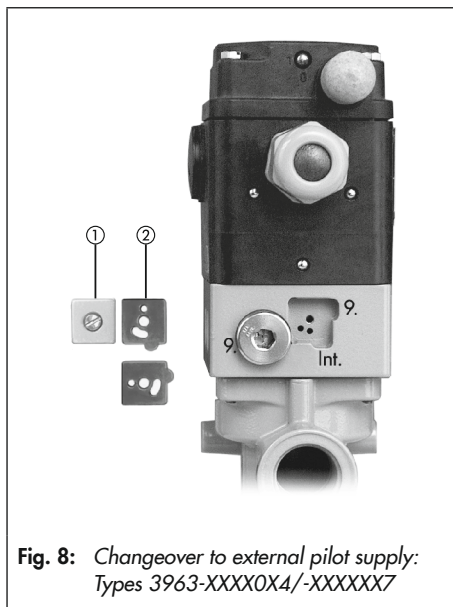

Fig. 8: Changeover to external pilot supply: Types 3963-XXXX0X4/-XXXXXX7

Types 3963-XXXX0X3/-XXXX006

The supply air in these solenoid valves is fed internally over port 1 or 3, if not specified otherwise. To change to an external supply over port 9, proceed as follows:

1. Undo the cap screw on the connection plate and remove plate ① and gasket ②.
2. Turn the gasket ② 180°. The tip of gasket ② must rest in the plate cut-out marked '9'.

3. Fasten the plate ① and gasket ② to the connection plate.

The changeover must be performed on both pilot valves for poppet valves actuated on both sides.

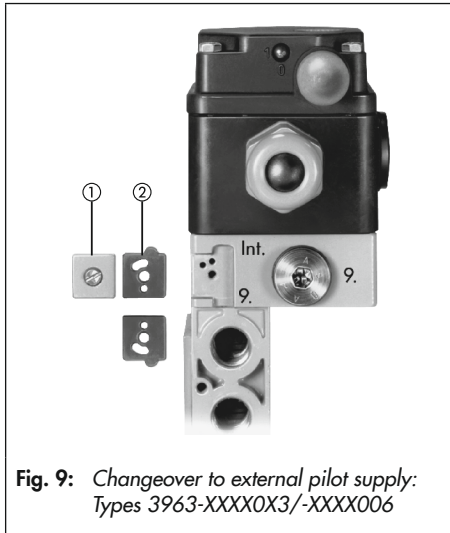

**Type 3963-XXX0002/-XXX0012/
-XXX0022/-XXX1011**

The supply air in these solenoid valves is fed internally over port 4, if not specified otherwise. To change to an external supply over port 9, proceed as follows (Fig. 10):

1. Undo the four cap screws and remove the enclosure cover.
2. Undo the three hex socket head cap screws and remove the solenoid valve from the connecting plate.

3. Turn the gasket 180°. The tip of gasket must rest in the device cut-out marked '9'.
4. Fasten the solenoid valve and enclosure cover.

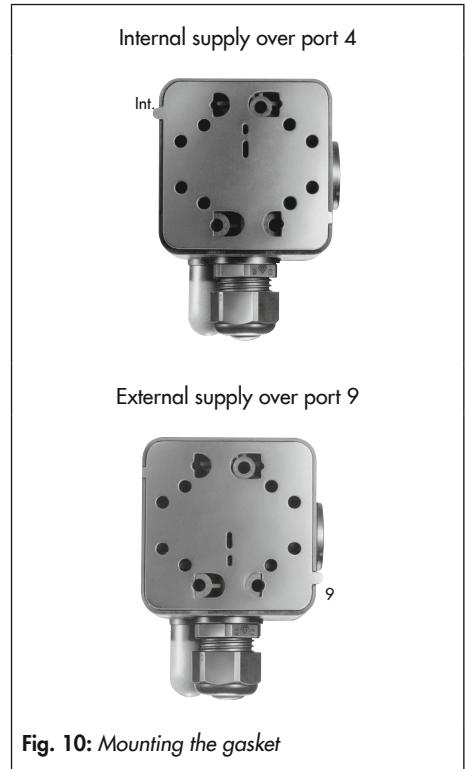

**Type 3963-XXXX001/-XXX0011/
-XXX0X3X/-XXX0101/-XXX0111/
-XXX1001/-XXX1201/-XXX8001**

It is not possible to convert these solenoid valves to accept an external pilot supply. The gasket, if it exists, must be inserted as

Mounting and start-up

specified for "Internal pilot supply at port 4" (Fig. 10).

5.4 Exhaust air feedback

Type 3963-XXX0013X

In the delivered state, the port 4 of this device is sealed by a blanking plug. If the exhaust air feedback of actuators with spring return mechanism is to be used, remove the blanking plug and connect port 4 to the actuator's spring chamber using a DN 4 to 10 connection line (the sizes depends on the actuator area).

5.5 Restrictors

Type 3963-XXXX1/-XXXX2/-XXXX3

These devices have one or two restrictors. The logic symbol on the device indicates the restriction function. Use a screwdriver to turn the restriction screws underneath the enclosure cover or at the adapter plate to adjust the closing and opening times in a ratio of 1:15.

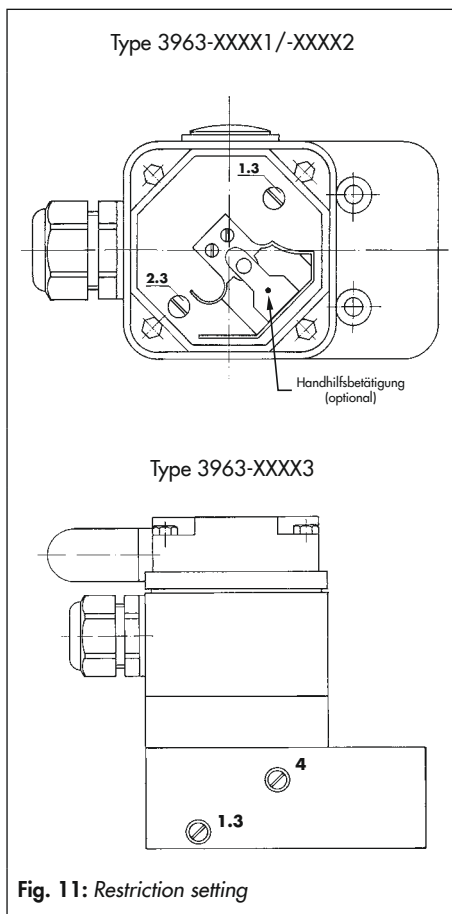

6 Electrical connection

⚠ DANGER

Risk of fatal injury due to electric shock.

- For electrical installation, observe the relevant electrotechnical regulations and the accident prevention regulations that apply in the country of use.
Valid regulations in Germany:
 - VDE regulations
 - Accident prevention regulations of the employers' liability insurance.

⚠ DANGER

Risk of fatal injury due to the formation of an explosive atmosphere.

- For installation in hazardous areas, observe the relevant standards that apply in the country of use.
Valid standards in Germany:
 - EN 60079-14: 2008 (VDE 0165, Part 1) Explosive Atmospheres – Electrical Installations Design, Selection and Erection.

⚠ WARNING

Incorrect electrical connection will render the explosion protection unsafe.

- Adhere to the terminal assignment.
- Do not undo the enameled screws in or on the enclosure.

⚠ WARNING

Intrinsic safety rendered ineffective in intrinsically safe devices.

- Only connect intrinsically safe devices intended for use in intrinsically safe circuits to certified intrinsically safe input-connected units.
- Do not place intrinsically safe devices back into operation that were connected to intrinsically safe input-connected units without certification.
- Do not exceed the maximum permissible electric values specified in the EC type examination certificates when interconnecting intrinsically safe electrical equipment (U_i or U_{0r} , I_i or I_{0r} , P_i or P_{0r} , C_i or C_0 and L_i or L_0).

Selecting cables and wires

- **Observe clause 12 of EN 60079-14: 2008 (VDE 0165, Part 1) for installation of the intrinsically safe circuits.**
- Clause 12.2.2.7 applies when running multi-core cables and wires with more than one intrinsically safe circuit.
- Preferably use connecting lines with minimum 0.5 mm² conductor cross-section and 6 to 12 mm outside diameter.
- **Radial thickness of the insulation** of a conductor for common insulating materials (e.g. polyethylene): **minimum 0.2 mm.**
- **Diameter of an individual wire** in a fine-stranded conductor: **minimum 0.1 mm.**

Electrical connection

- Protect the conductor ends against splicing, e.g. by using wire-end ferrules.
- Seal cable entries left unused with screw plugs.
- For use in ambient temperatures **below** **-20 °C**: use metal cable gland.

6.1 Switching amplifier according to EN 60079-25

For operation of the solenoid valve, switching amplifiers must be connected in the output circuit. They must comply with the limit values of the output circuits.

- Observe the relevant regulations for installation in hazardous areas.

Equipment for use in zone 2

In equipment operated according to type of protection Ex nA II (non-sparking equipment) according to EN 60079-15: 2003:

- Circuits may be connected, interrupted or switched while energized only during installation, maintenance or repair.

6.2 Cable entry with cable gland

The electrical connection is made using an M20x1.5 cable gland to the terminals in the enclosure or using a connector (see Fig. 12).

- The cable gland design depends on the ambient temperature range. See technical data in Chapter 3.2.
- When two separate cables are used for connection, an additional cable gland can be installed.

6.3 Connecting the electrical supply

- Connect the electrical power (voltage) as shown in Fig. 12.

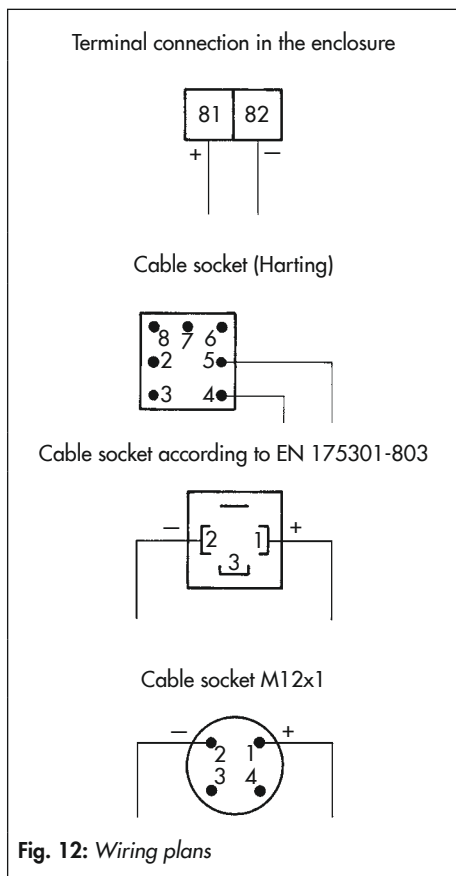

7 Operation

The solenoid valve is ready for use when mounting and start-up have been completed.

7.1 Degree of protection

Devices with a rating of IP 54 can be converted to a rating of IP 65 by exchanging the filter in the enclosure cover.

7.2 Manual override

The devices can be optionally fitted with a manual override to allow the device to be manually operated when a nominal signal is not available:

- As switch in the enclosure cover
- As pushbutton in the enclosure cover
- As pushbutton underneath the enclosure cover

We recommend using devices **without manual override** for **safety circuits**.

Table 2: *Troubleshooting*

Malfunction	Possible reasons	Recommended action
The solenoid valve does not switch.	Incorrect terminal assignment.	Check electrical connection.
	Turn turnable gasket to external pilot supply.	Connect port 9 and supply it with compressed air. Alternatively, turn the turnable gasket to internal pilot supply.
The solenoid valve leaks to the atmosphere.	Gasket slipped.	Check that the formed seal and O-rings are correctly seated.
	Pilot pressure is insufficient and an intermediate position of the solenoid valve is reached (air is constantly vented)	Check the pressure line. Check the pressure line for leakage. Use a larger cross-section for the pressure line.

8 Servicing

⚠ WARNING

Intrinsic safety rendered ineffective in intrinsically safe devices.

- *Only connect intrinsically safe devices intended for use in intrinsically safe circuits to certified intrinsically safe input-connected units.*
 - *Do not place intrinsically safe devices back into operation that were connected to intrinsically safe input-connected units without certification.*
 - *Do not exceed the maximum permissible electric values specified in the EC type examination certificates when interconnecting intrinsically safe electrical equipment (U_i or U_o , I_i or I_o , P_i or P_o , C_i or C_o and L_i or L_o).*
-

i Note

The solenoid valve was checked by SAMSON before delivery.

- *The product warranty becomes void if service or repair work not described in these instructions is performed without prior agreement by SAMSON's After-sales Service.*
 - *Only use original spare parts by SAMSON, which comply with the original specifications (see Data Sheet ► T 3963)*
-

8.1 Preparation for return shipment

Defective solenoid valves can be returned to SAMSON for repair.

Proceed as follows to return devices to SAMSON:

1. Put the control valve out of operation. See associated valve documentation.
2. Remove the solenoid valve (see Chapter 10).
3. Proceed as described on our website at www.samsongroup.com > Service > After-sales Service > Returning goods.

9 Malfunctions

i Note

Contact SAMSON's After-sales Service for malfunctions not listed in Table 2 (see Chapter 11.1).

9.1 Emergency action

The solenoid valve has a safety function. Upon failure of the supply voltage or air supply, it automatically closes (closed in the de-energized state).

Plant operators are responsible for emergency action to be taken in the plant.

10 Decommissioning and removal

⚠ DANGER

Risk of fatal injury due to electric shock.

- Before performing any work on the device and before opening the device, disconnect the supply voltage and protect it against unintentional reconnection.
 - Only use power interruption devices that are protected against unintentional reconnection of the power supply.
-

⚠ DANGER

Risk of bursting in control valve components due to incorrect opening.

- Before starting any work on the solenoid valve, depressurize all plant sections affected.
 - Observe the warnings in the actuator and valve documentation.
-

10.1 Decommissioning

To decommission the solenoid valve for disassembly, proceed as follows:

1. Close the shut-off valves upstream of the solenoid valve to stop the compressed air from flowing through the solenoid valve.
2. Relieve the pipelines completely of pressure.
3. Disconnect and lock the supply voltage.
4. Remove the solenoid valve from the pipeline

10.2 Disposal



SAMSON ist ein in Europa
registrierter Hersteller,
zuständige Institution

► www.samsongroup.com >
About SAMSON > Environment,
Social & Governance > Material
Compliance > Waste electrical
and electronic equipment
(WEEE)
WEEE reg. no.: DE 62194439

i Note

We can provide you with a recycling passport according to PAS 1049 on request. Simply e-mail us at aftersaleservice@samsongroup.com giving details of your company address.

Tip

On request, we can appoint a service provider to dismantle and recycle the product.

- ➔ Observe local, national and international refuse regulations.
- ➔ Do not dispose of components, lubricants and hazardous substances together with your other household waste.

11 Appendix

11.1 After-sales Service

Contact SAMSON's After-sales Service for support concerning service or repair work or when malfunctions or defects arise.

E-mail address

You can reach our after-sales service at aftersaleservice@samsongroup.com.

Addresses of SAMSON AG and its subsidiaries

The addresses of SAMSON AG and sales sites can be found on our website (www.samsongroup.com).

Required specifications

Please submit the following details:

- Order number and position number in the order
- Type designation and model number or configuration ID
- Other mounted valve accessories (positioner, supply pressure regulator etc.)
- Pressure
- Wire cross-section
- Actuator type and manufacturer



TRANSLATION

(1) **EC TYPE EXAMINATION CERTIFICATION**

(2) Equipment and Protective Systems Intended for Use in Potentially Explosive Atmospheres –
Directive 94/9/EC

(3) EC Type Examination Certificate Number

PTB 01 ATEX 2085

(4) Equipment: Solenoid Valve Model 3963-1..

(5) Manufacturer: SAMSON AG

(6) Address: Weismüllerstr. 3, D-60314 Frankfurt, Germany

(7) The equipment and any acceptable variations thereof are specified in the schedule to this certificate.

(8) The Physikalisch-Technische Bundesanstalt, notified body number 0102 according to Article 9 of the Council Directive 94/9/EC of 23 March 1994, certifies that this equipment has been found to comply with the Essential Health and Safety Requirements relating to the design and construction of equipment and protective systems intended for use in potentially explosive atmospheres specified in Annex II to the Directive.

The examination and test results are recorded in confidential report: **PTB Ex 01-21061**

(9) The Essential Health and Safety Requirements are satisfied by compliance with

EN 50014: 1997

EN 50020: 1994

EC Type Examination Certificates without signature and seal are invalid.
This EC Type Examination Certificate may only be reproduced in its entirety and without any changes, schedule included.
Extracts or changes shall require the prior approval of the Physikalisch-Technische Bundesanstalt.

Physikalisch-Technische Bundesanstalt, Bundesallee 100, D-38116 Braunschweig

Ptb23-3963.doc

- (10) If the sign "X" is placed after the certificate number, it indicates that the equipment is subject to special conditions for safe use as specified in the schedule to this certificate.
- (11) According to the Directive 94/9/EC, this EC TYPE EXAMINATION CERTIFICATE relates only to the design and construction of the specified equipment. If applicable, further requirements of this Directive apply to the manufacture and supply of this equipment.
- (12) The marking of the equipment shall include the following:



II 2 G EEx ia IIC T6

Zertifizierungsstelle Explosionsschutz
By order

Braunschweig, 8. August 2001

(Signature)

(Seal)

Dr. Ing. U. Johannsmeyer
Regierungsdirektor

EC Type Examination Certificates without signature and seal are invalid.
This EC Type Examination Certificate may only be reproduced in its entirety and without any changes, schedule included.
Extracts or changes shall require the prior approval of the Physikalisch-Technische Bundesanstalt.

Physikalisch-Technische Bundesanstalt, Bundesallee 100, D-38116 Braunschweig

Ptb23-3963.doc

Schedule

(13)

(14) **EC TYPE EXAMINATION CERTIFICATE No. PTB 01 ATEX 2085**

(15) **Description of Equipment**

The Model 3963-1.. Solenoid Valve converts electrical binary signals in the input circuit into pneumatic output signals. It is intended for attachment to actuators and for constructing control systems.

It may be installed inside and outside of hazardous areas.

The Model 3963-1.. Solenoid Valve is a passive two-terminal network that may be connected to any certified intrinsically safe circuit, provided the permissible maximum values of U_i , I_i and P_i are not exceeded.

By connection of suitable series dropping resistors the Model 3963-1.. Solenoid Valve can accommodate nominal voltages of 6, 12 V and 24 V.

Electrical data

Signal circuit normal signal ... Type of protection: Intrinsic Safety EEx ia IIC

The correlation between version, temperature classification, permissible maximum ambient temperature ranges and maximum power dissipation is shown in the table below:

Version (UN)		6V	12V	24V
Temperature class	T6	60°C $-45^{\circ}\text{C} \leq T_a \leq 70^{\circ}\text{C}$ 80°C		
	T5			
	T4			
Characteristic linear or rectangular	Pi	#	##	
C _i negligible, L _i negligible				

The permissible maximum power dissipation P_i in the 6 V version is 250 mW.

The maximum values for connection to a certified intrinsically safe circuit are shown in the table below:

EC Type Examination Certificates without signature and seal are invalid.
This EC Type Examination Certificate may only be reproduced in its entirety and without any changes, schedule included.
Extracts or changes shall require the prior approval of the Physikalisch-Technische Bundesanstalt.

U _i	25V	27V	28V	30V	32V
I _i	150mA	125mA	115mA	100mA	85mA
P _i	no limitation				
C _i negligible, L _i negligible					

(16) Test Report **PTB Ex 01-21061**

(17) **Special conditions for safe use**

None

(18) **Special Health and Safety Requirements**

In compliance with the standards specified above.

Zertifizierungsstelle Explosionsschutz
By order

Braunschweig, 8 August 2001

(Signature) (seal)

Dr. Ing. U. Johannsmeyer
Regierungsdirektor

EC Type Examination Certificates without signature and seal are invalid.
This EC Type Examination Certificate may only be reproduced in its entirety and without any changes, schedule included.
Extracts or changes shall require the prior approval of the Physikalisch-Technische Bundesanstalt.

Physikalisch-Technische Bundesanstalt., Bundesallee 100, D-38116 Braunschweig

Ptb23-3963.doc

1. SUPPLEMENT

according to Directive 94/9/EC Annex III.6

to EC-TYPE-EXAMINATION CERTIFICATE PTB 01 ATEX 2085

(Translation)

Equipment: Solenoid, type 3963-1.. and type 3963-1.....25

Marking:  II 2 G Ex ia IIC T6 Gb **alternatively** II 2 G Ex ia IIC T6

Manufacturer: SAMSON AG Mess- und Regeltechnik

Address: Weismüllerstr. 3, 60314 Frankfurt, Germany

Description of supplements and modifications

The solenoid of type 3963-1.. converts binary electrical signals of the input circuit into pneumatic output signals. It is mounted on actuators and used for the design of control systems.

The equipment is intended for the installation in hazardous areas.

The solenoid of type 3963-1.. is a passive two-terminal network that may be connected to intrinsically safe circuits unless the permissible maximum values for U_i , I_i and P_i are exceeded.

Using appropriate resistors connected in series to the coil, the solenoid of type 3963-1.. is suitable for the operation with nominal voltages of 6 V, 12 V and 24 V.

The solenoid of type 3963-1.. is supplemented by type 3963-1.....25. This variant is provided with an electrical cubic LED-plug showing the operating mode of the equipment. Further modifications have not been made.

The permissible thermal and electrical maximum values are presented in summary.

Electrical data

Signal circuit, nominal signal.....type of protection Intrinsic Safety Ex ia IIC

For relationship between variant, temperature class, permissible ambient temperature ranges and maximum power dissipation, reference is made to the following table:

Sheet 1/2

EC-type-examination Certificates without signature and official stamp shall not be valid. The certificates may be circulated only without alteration. Extracts or alterations are subject to approval by the Physikalisch-Technische Bundesanstalt. In case of dispute, the German text shall prevail.

Physikalisch-Technische Bundesanstalt • Bundesallee 100 • 38116 Braunschweig • GERMANY

Z5Ex10101e.d01m

Physikalisch-Technische Bundesanstalt



Braunschweig und Berlin

1. SUPPLEMENT TO EC-TYPE-EXAMINATION CERTIFICATE PTB 01 ATEX 2085

Variant		3963-11..	3963-12..	3963-13..
U_N		6 V	12 V	24 V
3936-1..	T6	60 °C		
	T5	-45 °C ... 70 °C		
	T4	80 °C		
3936-1.....25	T6	55 °C		
	T5	-45 °C ... 70 °C		
	T4	80 °C		
linear or rectangular characteristic	P_i	*	**	

* The maximum permissible power dissipation P_i of the 6 V-design is 250 mW.

** The maximum values for connection to a certified intrinsically safe circuit are tabulated below:

U_i	25 V	27 V	28 V	30 V	32 V
I_i	150 mA	125 mA	115 mA	100 mA	85 mA
P_i	no limitation				

C_i negligibly low

L_i negligibly low

Applied standards

EN 60079-0:2009

EN 60079-11:2012

Test report: PTB Ex 12-22145

Zertifizierungssektor Elektrotechnik
On behalf of PTB:

Braunschweig, November 28, 2012

Dr.-Ing. U. Johannsmeier
Direktor und Professor



Sheet 2/2

EC-type-examination Certificates without signature and official stamp shall not be valid. The certificates may be circulated only without alteration. Extracts or alterations are subject to approval by the Physikalisch-Technische Bundesanstalt. In case of dispute, the German text shall prevail.

Physikalisch-Technische Bundesanstalt • Bundesallee 100 • 38116 Braunschweig • GERMANY

[translation of German original]

Physikalisch-Technische Bundesanstalt
Braunschweig and Berlin

[hexagonal Ex logo]

[PTB logo]

[federal eagle logo]

(1) **EU-Type Examination Certificate**

(2) Equipment and protective systems intended for use in potentially explosive atmospheres
– **Directive 2014/34/EU**

(3) EU-type examination certificate number

PTB 01 ATEX 2085 Issue: 01

(4) Product: Type 3963-1..... .. Solenoid Valve

(5) Manufacturer: SAMSON AG

(6) Address: Weismüllerstraße 3, 60314 Frankfurt am Main, Germany

(7) The design of this product and the various permitted versions are defined in the Annex and the listed documents associated with this type-examination certificate.

(8) The Physikalisch-Technische Bundesanstalt (notified body no. 0102 according to Article 17 of the Directive 2014/34/EU of the European Parliament and of the Council of 26 February 2014) certifies that this product meets the essential health and safety requirements relating to the design and construction of products intended for use in potentially explosive atmospheres in accordance with Annex II of the Directive.

The test results are recorded in the confidential test report PTB Ex 19-27051.

(9) The essential health and safety requirements are met by compliance with
EN 60079-0:2012+A11:2013 EN 60079-11:2012

(10) The 'X' mark after the certification number refers to the special conditions for the safe use of the product in the Annex of this certificate.

(11) This EU-type examination certificate only applies to the design and testing of the specified product according to Directive 2014/34/EU. Other requirements of this directive apply to the manufacture and placing on the market for the first time. This certificate does not cover these requirements.

(12) The marking of the product must contain the following details:

 **II 2 G Ex ia IIC T6...T4 Gb**

Conformity Assessment Body, Explosion Protection Braunschweig, 18 November 2019
O/o

[signature F. Lienesch,
round stamp with federal eagle logo and
Physikalisch Technische Bundesanstalt 56 lettering]

Dr.-Ing. F. Lienesch
Director and Professor

Page 1/3

EU-type examination certificates without signature nor seal are invalid. This EU-type examination certificate may only be reproduced without changes. Excerpts or modifications are to be approved by Physikalisch-Technische Bundesanstalt.

Physikalisch-Technische Bundesanstalt · Bundesallee 100 · 38116 Braunschweig · Germany

Annex

(13)

(14) **EU-Type Examination Certificate PTB 01 ATEX 2085, Issue: 01**(15) Product description

The solenoid valve converts binary electrical signals in the input circuit into pneumatic output signals. It is designed for attachment to actuators and for implementing control loops. The solenoid valve is designed for installation in hazardous areas.

The solenoid valve is a passive two-pole unit suitable for connection to certified intrinsically safe power circuits, provided the permissible maximum values for U_i , I_i and P_i are not exceeded.

The solenoid valve is suitable for rated voltages of 6, 12 and 24 V. Optionally, it is equipped with an electrical rectangular connector with LED to indicate the operating state of the solenoid valve.

The following table lists the relation between the temperature class and the permissible ambient temperature ranges for gas group IIC:

Version	Temperature class	Ambient temperature range
Without electrical rectangular connector with LED	T6	-45 to +60 °C
	T5	-45 to +70 °C
	T4	-45 to +80 °C
With electrical rectangular connector with LED (Type 3963-1.....25)	T6	-45 to +55 °C
	T5	-45 to +70 °C
	T4	-45 to +80 °C

Electrical data:

Signal circuit..... in type of protection intrinsic safety Ex ia IIC (+81, -82)

For connection to a certified intrinsically safe current circuit only

Max. values:

For Type 3963-11..... (version with 6 V rated signal)

U_i = 32 V

I_i = 150 mA

P_i = 250 mW

L_i negligibly small

C_i negligibly small

For all remaining versions (12 V and 24 V
rated signal)

$U_i = 32 \text{ V}$

$I_i = 150 \text{ mA}$

L_i negligibly small

C_i negligibly small

Modifications with regard to former issues:

The modifications concern the updating of the test specifications, the marking and electrical data.

(16) Test report PTB Ex 19-27051

(17) Special conditions

None

(18) Essential health and safety requirements

Met through compliance with the above listed standards.

According to Article 41 of the Directive 2014/34/EU, EC-type examination certificates issued under Directive 94/9/EC, which were issued before the Directive 2014/34/EU came into force (20 April 2016), may be considered as if they were already issued to comply with Directive 2014/34/EU. With authorization of the European Commission, addenda to such EC-type examination certificates and new issues of such certificates may still bear the original certificate number issued before 20 April 2016.

Conformity Assessment Body, Explosion Protection
O/o

Braunschweig, 18 November 2019

[signature F. Lienesch,
round stamp with federal eagle logo and
Physikalisch Technische Bundesanstalt 56 lettering]

Dr.-Ing. F. Lienesch
Director and Professor



(1) **EU-TYPE EXAMINATION CERTIFICATE**
(Translation)

- (2) Equipment or Protective Systems Intended for Use in Potentially Explosive Atmospheres - **Directive 2014/34/EU**
- (3) EU-Type Examination Certificate Number:

PTB 01 ATEX 2085

Issue: 01

- (4) Product: Solenoid valve, type 3963-1.
- (5) Manufacturer: SAMSON AG
- (6) Address: Weismüllerstraße 3, 60314 Frankfurt, Germany
- (7) This product and any acceptable variation thereto is specified in the schedule to this certificate and the documents therein referred to.
- (8) The Physikalisch-Technische Bundesanstalt, notified body No. 0102 in accordance with Article 17 of the Directive 2014/34/EU of the European Parliament and of the Council, dated 26 February 2014, certifies that this product has been found to comply with the Essential Health and Safety Requirements relating to the design and construction of products intended for use in potentially explosive atmospheres, given in Annex II to the Directive.
- The examination and test results are recorded in the confidential Test Report PTB Ex 19-27051.
- (9) Compliance with the Essential Health and Safety Requirements has been assured by compliance with:
EN 60079-0:2012+A11:2013 **EN 60079-11:2012**
- (10) If the sign "X" is placed after the certificate number, it indicates that the product is subject to the Specific Conditions of Use specified in the schedule to this certificate.
- (11) This EU-Type Examination Certificate relates only to the design and construction of the specified product in accordance to the Directive 2014/34/EU. Further requirements of the Directive apply to the manufacturing process and supply of this product. These are not covered by this certificate.
- (12) The marking of the product shall include the following:

 **II 2 G Ex ia IIC T6...T4 Gb**

Konformitätsbewertungsstelle, Sektor Explosionsschutz Braunschweig, November 18, 2019
On behalf of PTB:

Dr.-Ing. F. Lienesch
Direktor und Professor



sheet 1/3

EU-Type Examination Certificates without signature and official stamp shall not be valid. The certificates may be circulated only without alteration. Extracts or alterations are subject to approval by the Physikalisch-Technische Bundesanstalt. In case of dispute, the German text shall prevail.

Physikalisch-Technische Bundesanstalt • Bundesallee 100 • 38116 Braunschweig • GERMANY



SCHEDULE

(13)

(14) **EU-Type Examination Certificate Number PTB 01 ATEX 2085, Issue: 01**

(15) Description of Product

The solenoid valve converts binary electrical signals of the input circuit into pneumatic output signals. It is mounted on actuators and used for the design of control systems.

The equipment is intended for the installation in hazardous areas.

The solenoid valve is a passive two-terminal network that may be connected to intrinsically safe circuits unless the permissible maximum values for U_i , I_i and P_i are exceeded.

The solenoid valve is suitable for the operation with nominal voltages of 6 V, 12 V and 24 V. An optionally available variant is provided with an electrical cubic LED-plug showing the operating mode of the equipment.

For relationship between temperature classes and permissible ambient temperature ranges for gas group IIC, reference is made to the following table.

Variant	Temperature class	Ambient temperature range
Without cubic LED-plug	T6	-45 °C ... +60 °C
	T5	-45 °C ... +70 °C
	T4	-45 °C ... +80 °C
With cubic LED-plug (Typ 3963-1. 25)	T6	-45 °C ... +55 °C
	T5	-45 °C ... +70 °C
	T4	-45 °C ... +80 °C

Electrical data:

Signal circuit
(+ 81, - 82)

type of protection Intrinsic Safety Ex ia IIC
Only for connection to a certified intrinsically safe circuit
Maximum values:

for type 3963-11 (variant with nominal signal 6 V)

$U_i = 32 \text{ V}$
 $I_i = 150 \text{ mA}$
 $P_i = 250 \text{ mW}$
 L_i negligibly low
 C_i negligibly low

for all remaining variants (nominal signal 12 V and 24 V)

$U_i = 32 \text{ V}$
 $I_i = 150 \text{ mA}$
 L_i negligibly low
 C_i negligibly low

sheet 2/3

EU-Type Examination Certificates without signature and official stamp shall not be valid. The certificates may be circulated only without alteration. Extracts or alterations are subject to approval by the Physikalisch-Technische Bundesanstalt. In case of dispute, the German text shall prevail.

Physikalisch-Technische Bundesanstalt • Bundesallee 100 • 38116 Braunschweig • GERMANY



SCHEDULE TO EU-TYPE EXAMINATION CERTIFICATE PTB 01 ATEX 2085 , Issue: 01

Changes with respect to previous editions

The modifications concern the update of the test specification, the marking and the electrical data.

- (16) Test Report PTB Ex 19-27051
- (17) Specific conditions of use
none
- (18) Essential health and safety requirements
Met by compliance with the aforementioned standards.

According to Article 41 of Directive 2014/34/EU, EC-type examination certificates which have been issued according to Directive 94/9/EC prior to the date of coming into force of Directive 2014/34/EU (April 20, 2016) may be considered as if they were issued already in compliance with Directive 2014/34/EU. By permission of the European Commission supplements to such EC-type examination certificates and new issues of such certificates may continue to hold the original certificate number issued before April 20, 2016.

Konformitätsbewertungsstelle, Sektor Explosionsschutz
On behalf of PTB:

Braunschweig, November 18, 2019

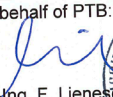
Dr.-Ing. F. Lienesch
Direktor und Professor



sheet 3/3

EU-Type Examination Certificates without signature and official stamp shall not be valid. The certificates may be circulated only without alteration. Extracts or alterations are subject to approval by the Physikalisch-Technische Bundesanstalt. In case of dispute, the German text shall prevail.

Physikalisch-Technische Bundesanstalt • Bundesallee 100 • 38116 Braunschweig • GERMANY



TRANSLATION



Statement of conformity

- (1)
- (2) Equipment and Protective Systems Intended for Use in Potentially Explosive Atmospheres –
Directive 94/9/EC
- (3) EC Type Examination Certificate Number

PTB 01 ATEX 2086 X

- (4) Equipment: Model 3963-8.. Solenoid Valve
- (5) Manufacturer: SAMSON AG Mess- und Regeltechnik
- (6) Address: Weismüllerstr. 3, 60314 Frankfurt am Main, Germany
- (7) The equipment and any acceptable variation thereof are specified in the schedule to this certificate and the documents referred to therein.
- (8) The Physikalisch-Technische Bundesanstalt, notified body number 0102 according to Article 9 of the Council Directive 94/9/ of 23 March 1994, certifies that this equipment has been found to comply with the essential health and safety requirements relating to the design and construction of equipment and protective systems intended for use in potentially explosive atmospheres specified in Annex II to the Directive.

The examination and test results are recorded in confidential report: **PTB Ex 01-21204**

- (9) The essential health and safety requirements are satisfied by compliance with
EN 50021: 1999
- (10) If the sign “X” is placed after the certificate number, it indicates that the equipment is subject to special conditions for safe use as specified in the schedule to this certificate.
- (11) In compliance with the Directive 94/9/Ex this Statement of Conformity relates only to the design and construction of the equipment specified. Further requirements of this Directive apply to manufacture and marketing of this equipment.

Statement of Conformity without signature and seal are invalid.
This Statement of Conformity may only be reproduced in its entirety and without any changes, schedule included.
Extracts or changes shall require the prior approval of the Physikalisch-Technische Bundesanstalt.

Physikalisch-Technische Bundesanstalt., Bundesallee 100, D-38116 Braunschweig

Ptb23-Ex n.doc

(12) The marking of the equipment shall include the following:



Zertifizierungsstelle Explosionsschutz
By order

Braunschweig, 14 November 2001

(Signature)

(Seal)

Dr. Ing. U. Johannsmeyer
Regierungsdirektor

Statement of Conformity without signature and seal are invalid.
This Statement of Conformity may only be reproduced in its entirety and without any changes, schedule included.
Extracts or changes shall require the prior approval of the Physikalisch-Technische Bundesanstalt.

Physikalisch-Technische Bundesanstalt., Bundesallee 100, D-38116 Braunschweig

Ptb23-Ex n.doc

(13) **S c h e d u l e**

(14) **Statement of Conformity PTB 01 ATEX 2086 X**

(15) **Description of Equipment**

The model 3963-8.. Solenoid Valve converts electrical binary signals in the input circuit into pneumatic output signals. It is intended for attachment to actuators and for constructing control systems.

The correlation between the version, temperature classification and permissible ambient temperature ranges is shown in the table below:

Version (UN)		6V	12V	24V
Temperature class	T6	60°C		
	T5	$-45^{\circ}\text{C} \leq T_a \leq 70^{\circ}\text{C}$		
	T4	80°C		

(16) **Test report PTB Ex 01-21204**

(17) **Special conditions for safe use**

1. The Model 3963-8.. Solenoid valve shall be installed in an enclosure providing at least Degree of Protection IP 54 according to IEC Publication 60529:1989.
2. The wiring shall be connected in such a manner that the connection facilities are free of tensile and torsional load.

(18) **Special health and safety requirements**

In compliance with the standard specified above.

Zertifizierungsstelle Explosionsschutz
By order

Braunschweig, 14 November 2001

(Signature) (seal)

Dr. Ing. U. Johannsmeyer
Regierungsdirektor

Statement of Conformity without signature and seal are invalid.
This Statement of Conformity may only be reproduced in its entirety and without any changes, schedule included.
Extracts or changes shall require the prior approval of the Physikalisch-Technische Bundesanstalt.

1. SUPPLEMENT
to CONFORMITY STATEMENT PTB 01 ATEX 2086 X
(Translation)

Equipment: Solenoid, type 3963-8..

Marking:  **II 3 G EEx nA II T6**

Manufacturer: SAMSON AG Mess- und Regeltechnik

Address: Weismüllerstr. 3, 60314 Frankfurt, Germany

Description of supplements and modifications

The solenoid of type 3963-8.. converts binary electrical signals into pneumatic output signals. It is intended for installation onto actuators and for the configuration of control systems.

The solenoid of type 3963-8.. is supplemented by type 3963-8.....25. This model is provided with a cubic LED-plug showing the operational state of the equipment.
Further modifications have not been made.

The equipment is installed inside of the hazardous area.

The permissible thermal and electrical maximum values are presented in summary.

For relationship between temperature class and permissible thermal maximum values, reference is made to the following table:

3963-8..	T6	60 °C
	T5	-45 °C ... 70 °C
	T4	80 °C
3963-8.....25	T6	55 °C
	T5	-45 °C ... 70 °C
	T4	80 °C

Electrical data

The solenoid of type 3963-8.. is suitable for nominal voltages of 6 V, 12 V and 24 V when appropriate resistors are connected in series.

Sheet 1/3

Conformity Statements without signature and official stamp shall not be valid. The certificates may be circulated only without alteration. Extracts or alterations are subject to approval by the Physikalisch-Technische Bundesanstalt. In case of dispute, the German text shall prevail.

Physikalisch-Technische Bundesanstalt • Bundesallee 100 • 38116 Braunschweig • GERMANY

ZSEx10201e.ddotm

1. SUPPLEMENT TO CONFORMITY STATEMENT PTB 01 ATEX 2086 X

For relationship between model, nominal signal and maximum permissible electrical power, reference is made to the following table:

Signal circuittype of protection Ex ic IIC
(terminals 11/12) or Ex nA II

Model	3963-81	3963-82	3963-83
Nominal signal U_N	6 V	12 V	24 V
Temperature class	60 °C		
	-45 °C ... 70 °C		
	80 °C		
P_i	No limitation		

or

Signal circuittype of protection Ex ic IIC
(terminals 11/12)

For permissible electrical maximum values, reference is made to the following table:

U_i	25 V	27 V	28 V	30 V	32 V
I_i	150 mA	125 mA	115 mA	100 mA	85 mA

C_i negligibly low
 L_i negligibly low

Special conditions

The solenoid of type 3963-8.. shall be mounted into an enclosure that guarantees a minimum degree of protection of IP 54 according to IEC 60529.

The cables shall be connected in such a way that the connecting points are not subjected to tensile or torsional stress.

All further specifications of the conformity statement apply without changes also to this supplement.

The future marking reads:

 **II 3 G Ex ic IIC T6 Gc** or **II 3 G Ex nA II T6 Gc** alternatively
II 3 G Ex ic IIC T6 or **II 3 G Ex nAc II T6**

Sheet 2/3

Conformity Statements without signature and official stamp shall not be valid. The certificates may be circulated only without alteration. Extracts or alterations are subject to approval by the Physikalisch-Technische Bundesanstalt. In case of dispute, the German text shall prevail.

Physikalisch-Technische Bundesanstalt • Bundesallee 100 • 38116 Braunschweig • GERMANY

Physikalisch-Technische Bundesanstalt



Braunschweig und Berlin

1. SUPPLEMENT TO CONFORMITY STATEMENT PTB 01 ATEX 2086 X

Applied standards

EN 60079-0:2009

EN 60079-11:2012

EN 60079-15:2010

Test report:

PTB Ex 14-23193

Zertifizierungssektor Explosionsschutz

By order:

Dr.-Ing. T. Horn



Braunschweig, April 17, 2014

Sheet 3/3

Conformity Statements without signature and official stamp shall not be valid. The certificates may be circulated only without alteration. Extracts or alterations are subject to approval by the Physikalisch-Technische Bundesanstalt. In case of dispute, the German text shall prevail.

Physikalisch-Technische Bundesanstalt • Bundesallee 100 • 38116 Braunschweig • GERMANY

SAMSON REGULATION S.A.S.



1/1

DC008
2021-12

DECLARATION UE DE CONFORMITE
EU DECLARATION OF CONFORMITY
EU KONFORMITÄTSERKLÄRUNG

La présente déclaration de conformité est établie sous la seule responsabilité du fabricant.
This declaration of conformity is issued under the sole responsibility of the manufacturer.
Die alleinige Verantwortung für die Ausstellung dieser Konformitätserklärung trägt der Hersteller.

Nous certifions pour les produits suivants en exécution standard :
For the following products in standard execution:
Für die folgenden Produkte in Standard-Ausführung:

Type / type / Typ : 2371, 3252, 3310, 3331, 3347, 3349, 3351, 3710, 3711, 3776, 3777, 3812, 3963,
3964, 3967, 4708, 4746, 5090, Samstation

sont conformes à la législation applicable harmonisée de l'Union :
the conformity with the relevant Union harmonization legislation is declared with:
wird die Konformität mit den einschlägigen Harmonisierungsrechtsvorschriften der Union bestätigt:

RoHS 2011/65/EU, 2015/863/EU

EN 50581:2012, IEC 63000:2016

Fabricant : SAMSON REGULATION S.A.S.
Manufacturer: 1, rue Jean Corona
Hersteller: 69520 Vaulx-en-Velin
France

Vaulx-en-Velin, le 14/12/21

Au nom du fabricant,
On behalf of the Manufacturer,
Im Namen des Herstellers,

SAMSON REGULATION S.A.S.

Joséphine SIGNOLES-FONTAINE
Responsable QSE

SAMSON REGULATION • 1 rue Jean Corona • 69120 Vaulx-en-Velin
Tél.: +33 (0)4 72 04 75 00 • Fax: +33 (0)4 72 04 75 75 • E-mail: samson@samson.fr • Internet: www.samson.fr

Société par actions simplifiée au capital de 10 000 000 € • Siège social : Vaulx-en-Velin
N° SIRET: RCS Lyon 8 788 165 605 00127 • N° de TVA: FR 88 788 165 603 • Code APE 2814Z

BNP Paribas

N° compte 0002200215245 • Banque 3000401857
IBAN FR7630004018570002200215245 • BIC (code SWIFT) BNPAFRPPVBE

Crédit Lyonnais

N° compte 00000600335841 • Banque 3000201936
IBAN FR883000201936000600335841 • BIC (code SWIFT) CRLYFRPP

Installation Manual for apparatus certified by CSA for use in hazardous locations.

Electrical rating of intrinsically safe apparatus and apparatus for installation in hazardous locations.

Table 1: Maximum values Solenoid valve

	U_i or V_{max}	I_i or I_{max}	P_i or P_{max}	C_i	L_i
12V/24V version	28V	115mA	not limited	0 nF	0 μ H
6 V version	28V	115mA	250mW	0 nF	0 μ H

$$U_0 \text{ or } V_{0c} \leq U_i \text{ or } V_{max} / I_0 \text{ or } I_{0c} \leq I_i \text{ or } I_{max} / P_0 \leq P_i \text{ or } P_{max}; C_a \geq C_i \text{ and } L_a \geq L_i$$

Table 2: CSA - certified barrier parameters of solenoid valve circuit

Barrier	Supply barrier		Evaluation barrier	
	V_{max}	R_{min}	V_{max}	
12V/24 V version	$\leq 28V$	$\geq 280\Omega$	$\leq 28V$	Diode Return
6 V version	$\leq 28V$	$\geq 280\Omega$	28V	Diode Return

Table 3: The correlation between temperature classification and permissible ambient temperature ranges is shown in the table below:

Temperature class	Permissible ambient temperature range
T6	- 45°C ... 60°C
T5	- 45°C ... 70°C
T4	- 45°C ... 80°C

Intrinsically safe if installed as specified in manufacturer's installation manual.

CSA-certified for hazardous locations

Ex ia IIC T6; Class I, Zone 0

Class I; Groups A, B, C, D;

Class II; Groups E, F + G; Class III

Type 4 Enclosure

Notes:

- 1.) The apparatus may be installed in intrinsically safe circuits only when used in conjunction with the CSA certified apparatus.
- 2.) For maximum values of U_i or V_{max} ; I_i or I_{max} ; P_i or P_{max} ; C_i and L_i of the various apparatus see Table 1 on page 1.
- 3.) For barrier selection see Table 2 on page 1.
- 4.) Installation shall be in accordance with the Canadian Electrical Code Part
- 5.) Use only supply wires suitable for 5°C above surrounding temperature.

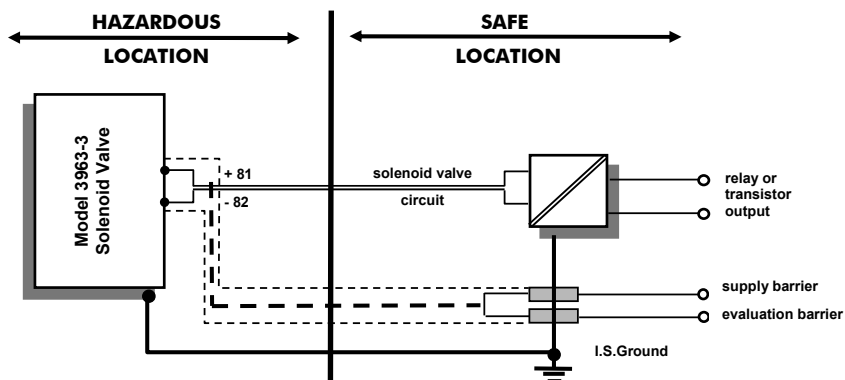

Version: Model 3963-3 Solenoid Valve.

Supply and evaluation barrier CSA- certified.

Cable entry M 20 x 1.5 or metal conduit according to drawing No. 1050 – 0539 T or 1050 – 0540 T

CSA- certified for hazardous locations

Class I; Div. 2, Groups A, B, C, D

Class II; Div. 2, Groups E, F + G, Class III

Type 4 Enclosure

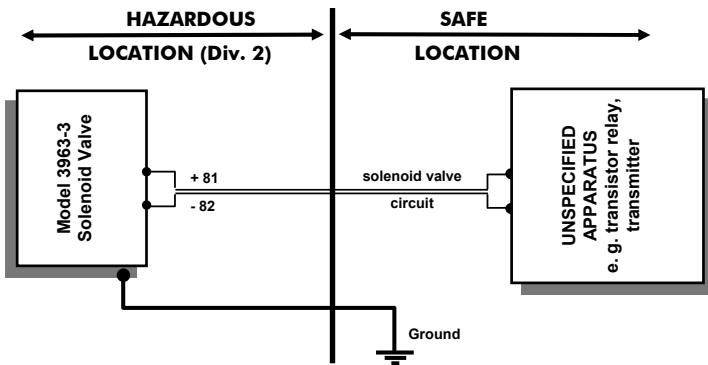

Notes:

- 1.) Cable entry only rigid metal conduit according to drawing No. 1050-0539 T and 1050-0540 T

Installation Manual for apparatus approved by FM for use in hazardous locations.

Electrical rating of intrinsically safe apparatus and apparatus for installation in hazardous locations.

Table 1: Maximum values

	U_i or V_{max}	I_i or I_{max}	P_i or P_{max}	C_i	L_i
Solenoid valve 12V/24 V version	28V	115mA	No limitation	0nF	0 μH
Solenoid valve 6 V version	28V	115 mA	250mW	0nF	0 μH

Notes: U_0 or V_{0c} or $V_t \leq U_i$ or V_{max} / I_0 or I_{sc} or $I_t \leq I_i$ or I_{max}
 P_0 or $P_{max} \leq P_i$ or P_{max}

Table 2: FM - approved barrier parameters of solenoid valve circuit

Barrier	Supply barrier			Evaluation barrier		
	V_{0c}	R_{min}	I_{sc}	V_{0c}	R_{min}	I_{sc}
Solenoid valve 12V/24 V version	≤ 28V	≥ 240Ω	≤ 115mA	≤ 28V	#	0mA
Solenoid valve 6 V version	≤ 28V	≥ 785Ω	≤ 115mA	≤ 28V	#	0mA

Table 3: The correlation between temperature classification and permissible ambient temperature ranges is shown in the table below:

Temperature class	Permissible ambient temperature range
T6	60°C
T5	- 45°C ≤ ta ≤ 70°C
T4	80°C

WARNING! In hazardous areas, make sure to install and service the device in such a way that electrostatic charging cannot take place.

Intrinsically safe if installed as specified in manufacturer's installation manual.

FM- approved for hazardous locations

Class I; Zone 0; A Ex ia IIC T6

Class I, II, III; Division 1; Groups A, B, C, D, E, F + G

NEMA 4X

Notes:

- 1.) The apparatus may be installed in intrinsically safe circuits only when used in conjunction with the FM approved apparatus. For maximum values of U_i or V_{max} ; I_i or I_{max} ; P_i or P_{max} ; C_i and L_i of the various apparatus see Table 1.
- 2.) The apparatus may be installed in intrinsically safe circuit only when used in conjunction with the FM approved intrinsically safe barrier. For barrier selection see Table 2.
- 3.) Installation shall be in accordance with the National Electrical Code ANSI/NFPA 70 and ANSI/ISA RP 12.06.01
- 4.) Use only supply wires suitable for 5°C above surrounding temperature.

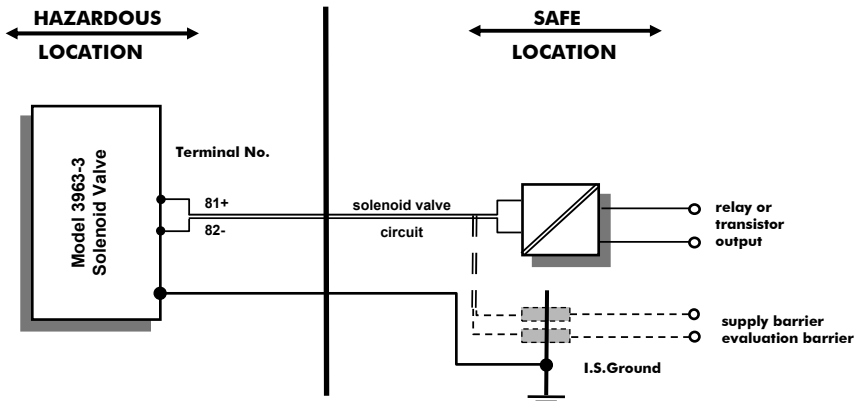

Version: Model 3963-3 solenoid valve.

Supply and emulation barrier FM/CSA- approved.

For the permissible maximum values for the intrinsically safe circuit see Table 1

For the permissible barrier parameters for the circuit see Table 2

Cable entry M 20 x 1.5 or metal conduit according to drawing No. 1050 – 0539 T or 1050 – 0540 T

FM- approved for hazardous locations

Class I; Division 2; Groups A, B, C, D

Class I; Class II Division 2; Groups F + G; Class III

NEMA 4X

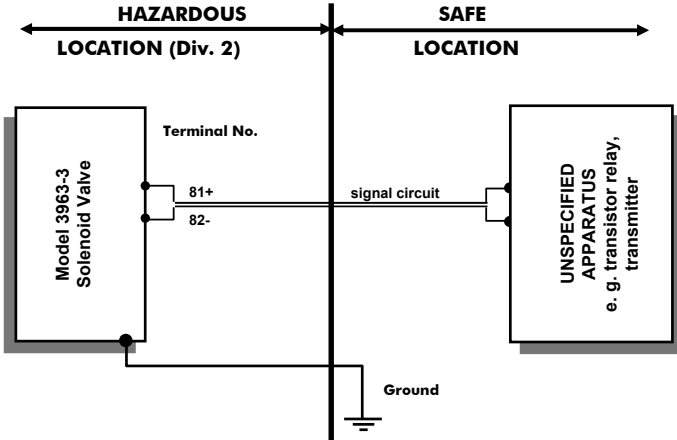

Notes:

- 1.) For the maximum values for the individual circuit see Table 1 and 2.
- 2.) Cable entry only rigid metal conduit according to drawing No. 1050-0539 T and 1050-0540 T
- 3.) The installation shall be in accordance with the National Electrical Code ANSI/NFPA 70



EU Konformitätserklärung / EU Declaration of Conformity / Déclaration UE de conformité

Die alleinige Verantwortung für die Ausstellung dieser Konformitätserklärung trägt der Hersteller/
This declaration of conformity is issued under the sole responsibility of the manufacturer/
La présente déclaration de conformité est établie sous la seule responsabilité du fabricant.
Für das folgende Produkt / For the following product / Nous certifions que le produit

Magnetventil / Solenoid Valve / Electrovanne Typ/Type/Type 3963

wird die Konformität mit den einschlägigen Harmonisierungsrechtsvorschriften der Union bestätigt /
the conformity with the relevant Union harmonisation legislation is declared with/
est conforme à la législation d'harmonisation de l'Union applicable selon les normes:

EMC 2014/30/EU	EN 61000-6-2:2005, EN 61000-6-3:2007/ A1:2010, EN 61326-1:2013
LVD 2014/35/EU	EN 61010-1:2010
RoHS 2011/65/EU	EN 50581:2012

Hersteller / Manufacturer / Fabricant:

SAMSON AKTIENGESELLSCHAFT
Weismüllerstraße 3
D-60314 Frankfurt am Main
Deutschland/Germany/Allemagne

Frankfurt / Francfort, 2017-07-29

Im Namen des Herstellers/ On behalf of the Manufacturer/ Au nom du fabricant.

Hanno Zager
Leiter Qualitätssicherung/Head of Quality Management/
Responsable de l'assurance de la qualité

Dirk Hoffmann
Zentralabteilungsleiter/Head of Department/Chef du département
Entwicklungsorganisation/Development Organization

es_3963.0_de_en_fr_eu07.pdf



EU Konformitätserklärung / EU Declaration of Conformity / Déclaration UE de conformité

Die alleinige Verantwortung für die Ausstellung dieser Konformitätserklärung trägt der Hersteller/
This declaration of conformity is issued under the sole responsibility of the manufacturer/
La présente déclaration de conformité est établie sous la seule responsabilité du fabricant.
Für das folgende Produkt / For the following product / Nous certifions que le produit

Magnetventil / Solenoid Valve / Electrovanne Typ/Type/Type 3963-1...

entsprechend der EU-Baumusterprüfbescheinigung PTB 01 ATEX 2085 ausgestellt von der/
according to the EU Type Examination PTB 01 ATEX 2085 issued by/
établi selon le certificat CE d'essais sur échantillons PTB 01 ATEX 2085 émis par:

Physikalisch Technische Bundesanstalt
Bundesallee 100
D-38116 Braunschweig
Benannte Stelle/Notified Body/Organisme notifié 0102

wird die Konformität mit den einschlägigen Harmonisierungsrechtsvorschriften der Union bestätigt/
the conformity with the relevant Union harmonisation legislation is declared with/
est conforme à la législation d'harmonisation de l'Union applicable selon les normes:

EMC 2014/30/EU	EN 61000-6-2:2019, EN 61000-6-3:2007 +A1:2011, EN 61326-1:2013
Explosion Protection 2014/34/EU	EN 60079-0:2012+A11:2013, EN 60079-11:2012
RoHS 2011/65/EU	EN 50581:2012

Hersteller / Manufacturer / Fabricant:

SAMSON AKTIENGESELLSCHAFT
Weismüllerstraße 3
D-60314 Frankfurt am Main
Deutschland/Germany/Allemagne

Frankfurt / Francfort, 2020-01-23

Im Namen des Herstellers/ On behalf of the Manufacturer/ Au nom du fabricant.

Dipl.-Ing. Jens Bieger
Zentralabteilungsleiter/Head of Department/Chef de département
Entwicklung Ventilanbaugeräte und Messtechnik
Development Valve Attachments and Measurement Technologies

Dipl.-Ing. Silke Bianca Schäfer
Total Quality Management/
Management par la qualité totale

ce_3963-1_de_en_fr_re03.pdf



EU Konformitätserklärung / EU Declaration of Conformity / Déclaration UE de conformité

Die alleinige Verantwortung für die Ausstellung dieser Konformitätserklärung trägt der Hersteller/
This declaration of conformity is issued under the sole responsibility of the manufacturer/
La présente déclaration de conformité est établie sous la seule responsabilité du fabricant.
Für das folgende Produkt / For the following product / Nous certifions que le produit

Magnetventil / Solenoid Valve / Typ/Type/Type 3963-8...

entsprechend der EU-Baumusterprüfbescheinigung PTB 01 ATEX 2086 X ausgestellt von der/
according to the EU Type Examination PTB 01 ATEX 2086 X issued by/
établi selon le certificat CE d'essais sur échantillons PTB 01 ATEX 2086 X émis par:

Physikalisch Technische Bundesanstalt
Bundesallee 100
D-38116 Braunschweig
Benannte Stelle/Notified Body/Organisme notifié 0102

wird die Konformität mit den einschlägigen Harmonisierungsrechtsvorschriften der Union bestätigt /
the conformity with the relevant Union harmonisation legislation is declared with/
est conforme à la législation d'harmonisation de l'Union applicable selon les normes:

EMC 2014/30/EU

EN 61000-6-2:2005, EN 61000-6-3:2007
+A1:2011, EN 61326-1:2013

Explosion Protection 94/9/EC (bis/to 2016-04-19)
Explosion Protection 2014/34/EU (ab/from 2016-04-20)

EN 60079-0:2009, EN 60079-11:2012,
EN 60079-15:2010

RoHS 2011/65/EU

EN 50581:2012

Hersteller / Manufacturer / Fabricant:

SAMSON AKTIENGESELLSCHAFT
Weismüllerstraße 3
D-60314 Frankfurt am Main
Deutschland/Germany/Allemagne

Frankfurt / Francfort, 2017-07-29

Im Namen des Herstellers/ On behalf of the Manufacturer/ Au nom du fabricant.

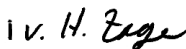

Hanno Zager
Leiter Qualitätssicherung/Head of Quality Management/
Responsable de l'assurance de la qualité

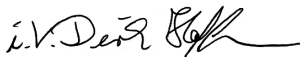

Dirk Hoffmann
Zentralabteilungsleiter/Head of Department/Chef de département
Entwicklungsorganisation/Development Organization

es_3963_8_dk_en_fr_en07.pdf



ЕВРАЗИЙСКИЙ ЭКОНОМИЧЕСКИЙ СОЮЗ ДЕКЛАРАЦИЯ О СООТВЕТСТВИИ

Заявитель Общество с ограниченной ответственностью "САМСОН КОНТРОЛС".

Основной государственный регистрационный номер: 1037700041026. Место нахождения и адрес места осуществления деятельности: 109544, город Москва, бульвар Энтузиастов, дом 2, этаж 5, комната 11, Российская Федерация. Телефон: +7 (495) 777-4545, адрес электронной почты: samson@samson.ru.

в лице Генерального директора Крымшамхалова Азрета Индрисовича, действующего на основании Устава.

заявляет, что Клапаны соленоидные торговой марки SAMSON, типы: 3701, 3962, 3963, 3964, 3965, 3966, 3967, 3969.

Изготовитель "SAMSON AKTIENGESELLSCHAFT".

Место нахождения: Weismuellerstrasse 3, 60314 Frankfurt am Main, Germany, Федеративная Республика Германия. Адреса мест осуществления деятельности по изготовлению продукции: Weismuellerstrasse 3, 60314 Frankfurt am Main, Germany, ("SAMSON AKTIENGESELLSCHAFT"), Федеративная Республика Германия, 1 rue Jean Corona, 69120 Vaulx-en-Velin, ("SAMSON REGULATION S.A.S."), Франция.

Продукция изготовлена в соответствии с 2014/30/EU "Electromagnetic compatibility directive" (2014/30/EU "Директива по электромагнитной совместимости").

Код ТН ВЭД ЕАЭС: 8481 20 900 9.

Серийный выпуск.

соответствует требованиям Технического Регламента Таможенного Союза ТР ТС 020/2011 "Электромагнитная совместимость технических средств".

Декларация о соответствии принята на основании эксплуатационной документации (Руководство по эксплуатации 3742-3962-2020.РЭ "Электромагнитные клапаны типа 3962. Руководство по эксплуатации"); протокола № 58-12-2020 от 24.12.2020, выданного Испытательной лабораторией Общества с ограниченной ответственностью "Испытательный центр".

Схема декларирования соответствия: Id.

Дополнительная информация разделы 5 и 7 ГОСТ 30804.3.2-2013 (IEC 61000-3-2:2009) "Совместимость технических средств электромагнитная. Эмиссия гармонических составляющих тока техническими средствами с потребляемым током не более 16 А (в одной фазе). Нормы и методы испытаний", раздел 5 ГОСТ 30804.3.3-2013 (IEC 61000-3-3:2008) "Совместимость технических средств электромагнитная. Ограничение изменений напряжения, колебаний напряжения и фликера в низковольтных системах электроснабжения общего назначения. Технические средства с потребляемым током не более 16 А (в одной фазе), подключаемые к электрической сети при несоблюдении определенных условий подключения. Нормы и методы испытаний".

Условия хранения: под навесами при температуре окружающего воздуха от минус 20 °С до плюс 40 °С и относительной влажности до 70%. Назначенный срок хранения: 24 месяца. Назначенный срок службы: 15 лет.

Декларация о соответствии действительна с даты регистрации

по 24.12.2025 включительно.

(подпись)



Крымшамхалов Азрет Индрисович

(Ф.И.О. заявителя)

Регистрационный номер декларации о соответствии:

ЕАЭС N RU Д-ДЕ.МХ.24.В.01411/20

Дата регистрации декларации о соответствии: 25.12.2020



ЕВРАЗИЙСКИЙ ЭКОНОМИЧЕСКИЙ СОЮЗ ДЕКЛАРАЦИЯ О СООТВЕТСТВИИ

Заявитель Общество с ограниченной ответственностью "САМСОН КОНТРОЛС".
Основной государственный регистрационный номер: 1037700041026. Место нахождения и адрес
места осуществления деятельности: 109544, город Москва, бульвар Энтузиастов, дом 2, этаж 5,
комната 11, Российская Федерация. Телефон: +7 (495) 777-4545, адрес электронной почты:
samson@samson.ru.

в лице Генерального директора Крымшамхалова Азрета Индрисовича, действующего на основании
Устава.

заявляет, что Клапаны соленодные торговой марки SAMSON, типы: 3701, 3962, 3963, 3966.

Изготовитель "SAMSON AKTIENGESELLSCHAFT".

Место нахождения: Weismuellerstrasse 3, 60314 Frankfurt am Main, Germany, Федеративная
Республика Германия. Адреса мест осуществления деятельности по изготовлению продукции:
Weismuellerstrasse 3, 60314 Frankfurt am Main, Germany, ("SAMSON AKTIENGESELLSCHAFT"),
Федеративная Республика Германия, 1 rue Jean Corona, 69120 Vaulx-en-Velin, ("SAMSON
REGULATION S.A.S."), Французская Республика.

Продукция изготовлена в соответствии с 2014/35/EU "Low Voltage Directive" (2014/35/EU "Директива
на низковольтное оборудование").

Код ТН ВЭД ЕАЭС: 8481 20 900 9

Серийный выпуск

соответствует требованиям Технического Регламента Таможенного Союза ТР ТС 004/2011
"О безопасности низковольтного оборудования".

Декларация о соответствии принята на основании эксплуатационной документации (Руководства
по эксплуатации 3742-3701-2020.РЭ, 3742-3962-2020.РЭ, 3742-3963-2020.РЭ, 3742-3966-2020.РЭ);
протокола № 1-02-2021 от 04.02.2021, выданного Испытательной лабораторией Общества с
ограниченной ответственностью "НПЦ "Воронеж-Эксперт".

Схема декларирования соответствия: 1д

Дополнительная информация ГОСТ 12.2.007.0-75 "Система стандартов безопасности труда.
Изделия электротехнические. Общие требования безопасности".

Условия хранения: в закрытых помещениях или других помещениях с естественной вентиляцией без
искусственно регулируемых климатических условий при температуре окружающего воздуха
от минус 50 °С до 50 °С и относительной влажности до 70%. Назначенный срок хранения: 24 месяца.

Назначенный срок службы: 15 лет.

Декларация о соответствии действительна с даты регистрации

по 09.02.2026

включительно.

(подпись)



Крымшамхалов Азрет Индрисович

(Ф.И.О. заявителя)

Регистрационный номер декларации о соответствии:

ЕАЭС N RU Д-ДЕ.РА01.В.89416/21

Дата регистрации декларации о соответствии: 10.02.2021

EB 3963 EN



SAMSON AKTIENGESELLSCHAFT
Weismüllerstraße 3 · 60314 Frankfurt am Main, Germany
Phone: +49 69 4009-0 · Fax: +49 69 4009-1507
samson@samsongroup.com · www.samsongroup.com