

MOUNTING AND OPERATING INSTRUCTIONS



EB 1015 EN

Translation of original instructions



Type 2 N and Type 2 NI Strainers

Edition March 2025



Note on these mounting and operating instructions

These mounting and operating instructions assist you in mounting and operating the device safely. The instructions are binding for handling SAMSON devices. The images shown in these instructions are for illustration purposes only. The actual product may vary.

- For the safe and proper use of these instructions, read them carefully and keep them for later reference.
- If you have any questions about these instructions, contact SAMSON's After-sales Service (aftersaleservice@samsongroup.com).



Documents relating to the device, such as the mounting and operating instructions, are available on our website at www.samsongroup.com > **Downloads > Documentation.**

Definition of signal words

DANGER

Hazardous situations which, if not avoided, will result in death or serious injury

WARNING

Hazardous situations which, if not avoided, could result in death or serious injury

NOTICE

Property damage message or malfunction

Note

Additional information

Tip

Recommended action

1	Safety instructions and measures	4
1.1	Notes on possible severe personal injury	6
1.2	Notes on possible personal injury	6
1.3	Notes on possible property damage	7
2	Markings on the device	8
2.1	Marking on the strainer body	8
2.2	Material identification number	9
3	Design and principle of operation	9
3.1	Technical data	9
4	Measures for preparation	14
4.1	Unpacking	14
4.2	Transporting and lifting	14
4.2.1	Transporting	15
4.2.2	Lifting.....	15
4.3	Storage.....	17
4.4	Preparation for installation.....	18
5	Mounting and start-up	18
5.1	Mounting positions.....	18
5.2	Additional fittings.....	19
5.3	Installing the strainer	20
5.4	Start-up.....	20
5.4.1	Gases and liquids	21
5.4.2	Steam	21
6	Servicing	21
6.1	Cleaning or exchanging the filter	23
6.2	Preparation for return shipment	23
6.3	Ordering spare parts and operating supplies	24
7	Malfunctions	24
7.1	Emergency action	24
8	Decommissioning and removal	25
8.1	Decommissioning	26
8.2	Disposal.....	26
9	Appendix	27
9.1	After-sales service	27
9.2	Spare parts, tightening torques and lubricant	28
9.3	Certificates	29

1 Safety instructions and measures

Intended use

The SAMSON Type 2 N and Type 2 NI Strainers are used to hold back large particles contained in liquids, gases and vapors. The strainers are designed to operate under exactly defined conditions (e.g. operating pressure, process medium, temperature). Therefore, operators must ensure that the strainers are only used in operating conditions that meet the specifications used for sizing the strainers at the ordering stage. In case operators intend to use the strainers in applications or conditions other than those specified, contact SAMSON. SAMSON does not assume any liability for damage resulting from the failure to use the device for its intended purpose or for damage caused by external forces or any other external factors.

➔ Refer to the technical data and nameplate for limits and fields of application as well as possible uses.

Reasonably foreseeable misuse

The strainers are not suitable for the following applications:

- Use outside the limits defined during sizing and by the technical data

Furthermore, the following activities do not comply with the intended use:

- Use of non-original spare parts
- Performing service and repair work not described

Qualifications of operating personnel

The strainer must be mounted, started up, serviced and repaired by fully trained and qualified personnel only; the accepted industry codes and practices must be observed. According to these mounting and operating instructions, trained personnel refers to individuals who are able to judge the work they are assigned to and recognize possible hazards due to their specialized training, their knowledge and experience as well as their knowledge of the applicable standards.

Personal protective equipment

SAMSON recommends checking the hazards posed by the process medium being used (e.g.

▶ GESTIS (CLP) hazardous substances database).

- Provide protective equipment (e.g. safety gloves, eye protection) appropriate for the process medium used.
- Wear hearing protection when working near the strainer.
- Check with the plant operator for details on further protective equipment.

Revisions and other modifications

Revisions, conversions or other modifications of the product are not authorized by SAMSON. They are performed at the user's own risk and may lead to safety hazards, for example. Furthermore, the product may no longer meet the requirements for its intended use.

Warning against residual hazards

To avoid personal injury or property damage, operators and operating personnel must prevent hazards that could be caused in the strainer by the process medium and operating pressure by taking appropriate precautions. Plant operators and operating personnel must observe all hazard statements, warnings and caution notes in these mounting and operating instructions, especially for installation, start-up and service work.

SAMSON also recommends checking the hazards posed by the process medium being used (e.g. ► GESTIS (CLP) hazardous substances database).

- Observe safety measures for handling the device as well as fire prevention and explosion protection measures.

Responsibilities of the operator

Operators are responsible for proper use and compliance with the safety regulations. Operators are obliged to provide these mounting and operating instructions as well as the referenced documents to the operating personnel and to instruct them in proper operation. Furthermore, operators must ensure that operating personnel or third parties are not exposed to any danger.

Responsibilities of operating personnel

Operating personnel must read and understand these mounting and operating instructions as well as the referenced documents and observe the specified hazard statements, warnings and caution notes. Furthermore, operating personnel must be familiar with the applicable health, safety and accident prevention regulations and comply with them.

Referenced standards, directives and regulations

The strainers comply with the requirements of the European Pressure Equipment Directive 2014/68/EU. Strainers with a CE marking have an EU declaration of conformity, which includes information about the applied conformity assessment procedure. This EU declaration of conformity is included in the Appendix of these instructions (see Chapter 9.3).

1.1 Notes on possible severe personal injury

DANGER

Risk of bursting in pressure equipment.

Strainers and pipelines are pressure equipment. Improper opening can lead to strainer components bursting.

- If necessary, a suitable overpressure protection must be installed on site in the plant section.
- Before starting any work on the strainer, depressurize all plant sections concerned.
- Drain the process medium from all the plant sections affected as well as from the strainer.
- Wear personal protective equipment.

1.2 Notes on possible personal injury

WARNING

Risk of personal injury due to residual process medium in the strainer.

While working on the strainer, residual process medium can escape and, depending on its properties, may lead to personal injury, e.g. (chemical) burns.

- If possible, drain the process medium from the plant sections affected and from the strainer.
- Wear protective clothing, safety gloves and eye protection.

⚠ WARNING**Risk of burn injuries due to hot or cold components and pipelines.**

Depending on the process medium, strainer components and pipelines may get very hot or cold and cause burn injuries.

- Allow components and pipelines to cool down or warm up to the ambient temperature.
- Wear protective clothing and safety gloves.

1.3 Notes on possible property damage

ⓘ NOTICE**Risk of the strainer becoming blocked due to contamination (e.g. solid particles) in the pipeline.**

The plant operator is responsible for cleaning the pipelines in the plant.

- Do not use the strainer to permanently filter the process medium.
- Observe the maximum permissible pressure for strainer and plant.

Risk of strainer damage due to unsuitable medium properties.

The strainer is designed for a process medium with defined properties.

- Only use the process medium specified for sizing the equipment.

Risk of strainer damage due to the use of unsuitable lubricants.

The lubricants to be used depend on the strainer material. Unsuitable lubricants may corrode and damage surfaces.

- Only use lubricants approved by SAMSON (see Chapter 9.2).

! NOTICE

Risk of leakage and strainer damage due to over- or under-torquing.

Observe the specified torques when tightening strainer components. Excessive tightening torques lead to parts wearing out more quickly. Parts that are too loose may cause leakage.

→ Observe the specified tightening torques (see Chapter 9.2).

2 Markings on the device

2.1 Marking on the strainer body

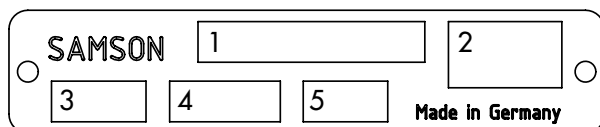

- 1 Material number and device index
- 2 CE marking, if applicable
- 3 Order number or year of manufacture
- 4 Type designation and mesh size
- 5 EAC

Fig. 1: *Marking on the strainer body*

The nameplate of all sizes is affixed to the body flange.

2.2 Material identification number

Specifying the material number, you can contact SAMSON to find out which material is used. It is specified on the nameplate (1, Mat. No. and device index). For more details on the nameplate, see Fig. 1.

3 Design and principle of operation

→ See Fig. 2

The Type 2 N and Type 2 NI Strainers consist of a Y-style body (1) with flanged connections, filter (2), seal (3) and a cover (4) for the filter.

The strainer installed upstream of the valve is used to hold back any dirt or other foreign particles carried along by the medium.

The process medium flows through the body in the direction indicated by the arrow.

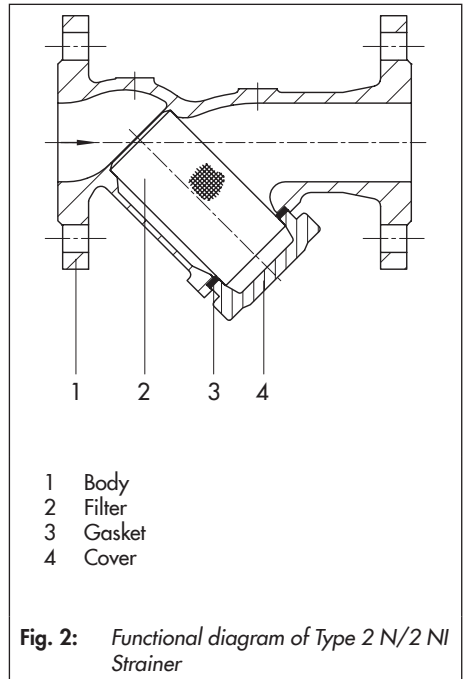

3.1 Technical data

The strainer body contains information on the strainer version (see Chapter 2.1).

Process medium and scope of application

The **Type 2 N and Type 2 NI** Strainers are suitable for use with **liquids, vapors and gases**.

Temperature range

The Type 2 N and Type 2 NI are designed for a temperature range from -10 to $+450$ °C (14 to 840 °F), depending on the body material.

Design and principle of operation

Noise emissions

SAMSON is unable to make general statements about noise emissions. The noise emissions depend on the strainer version, plant facilities and process medium.

WARNING

Risk of hearing loss or deafness due to loud noise.

Wear hearing protection when working near the strainer.

Dimensions and weights

Table 4 provides a summary of the dimensions and weights of Type 2 N and Type 2 NI Strainers. The lengths and heights in the dimensional drawing are shown in Fig. 3.

Table 1: Technical data

Type 2 N/Type 2 NI	
Port	Flanges DN 15 to 250
Max. permissible temperature ¹⁾	300 to 450 °C
EU declaration of conformity	CE

¹⁾ Depending on body material

Table 2: Materials · Material numbers according to DIN EN

Nominal size	DN 15 to 250	DN 15 to 150	DN 15 to 250	DN 15 to 100
Pressure rating	PN 10 ²⁾ · PN 16	PN 16 ³⁾ · PN 25	PN 16 ⁴⁾ · PN 25 ⁵⁾ · PN 40	PN 40
Body	Cast iron EN-GJL-250	Sph. graphite iron EN-GJS-400-18-LT	Cast steel 1.0619	Cast stainless steel 1.4408
Cover flange	EN-GJL-250	1.0460	1.0460 ¹⁾	1.4571
Filter	Stainless steel 1.4401			
Seal	Graphite on metal core			

¹⁾ DN 200 and 250: 1.0619

²⁾ With DN 200 and 250 only

³⁾ With DN 100 to 150 only

⁴⁾ DN 100 to 150 on request

⁵⁾ DN 200 and 250 on request

Table 3: K_{VS} coefficients · Flow resistance coefficient

Nominal size DN	15	20	25	32	40	50	65	80	100	125	150	200	250	
Type 2 N														
K_{VS}	m ³ /h	5	10	17.5	21	36	65	116	150	235	366	522	950	1450
Mesh size	mm	0.5		0.8			1.25			2				
Mesh count per cm ²		150		59			28			12				
Free filter area		Approx. 3 times pipe cross-section					Approx. 2.75 times pipe cross-section			Approx. 2.5 times pipe cross-section				
Flow resistance coefficient	ζ	2.5												
Type 2 NI ¹⁾														
K_{VS}	m ³ /h	4.5	8	14	18	29	51	90	115	190	290	450	760	1150
Mesh size	mm	0.25												
Mesh count per cm ²		625												
Free filter area		Approx. 3 times pipe cross-section					Approx. 2.75 times pipe cross-section			Approx. 2.5 times pipe cross-section				
Flow resistance coefficient	ζ	3												

¹⁾ Type 2 NI fulfills the requirements of DVGW (German Technical and Scientific Association for Gas and Water) according to DIN EN 161 when combined with a Type 3241 Valve.

Design and principle of operation

Table 4: *Dimensions in mm and weights*

Nominal size DN		15	20	25	32	40	50	65
PN 10 PN 16 PN 25 PN 40	Length L	130	150	160	180	200	230	290
	Height H1	45	60	70	85	95	115	150
	Height H2 (strainer insert pulled out)	75	90	110	135	160	195	225
	Weight, approx. kg	Spheroidal graphite iron/cast iron	1.9	2.8	3.3	5.4	6.5	9.1
Cast steel		2.2	3.2	4.0	5.8	7.2	10	14
Nominal size DN		80	100	125	150	200	250	
PN 10 PN 16 PN 25 PN 40	Length L	310	350	400	480	600	730	
	Height H1	180	224	255	290	385	480	
	Height H2 (strainer insert pulled out)	295	343	420	485	640	790	
	Weight, approx. kg	Spheroidal graphite iron/cast iron	17	24	36	52	91	152
Cast steel		19	28	42	60	130	195	

Dimensional drawings

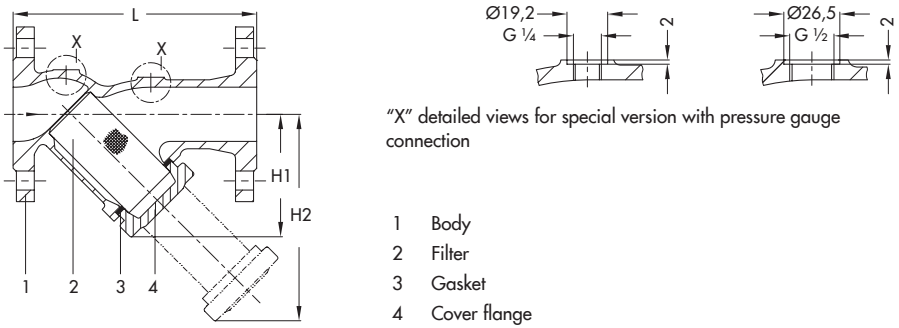

Fig. 3: Dimensions

Pressure-temperature diagram

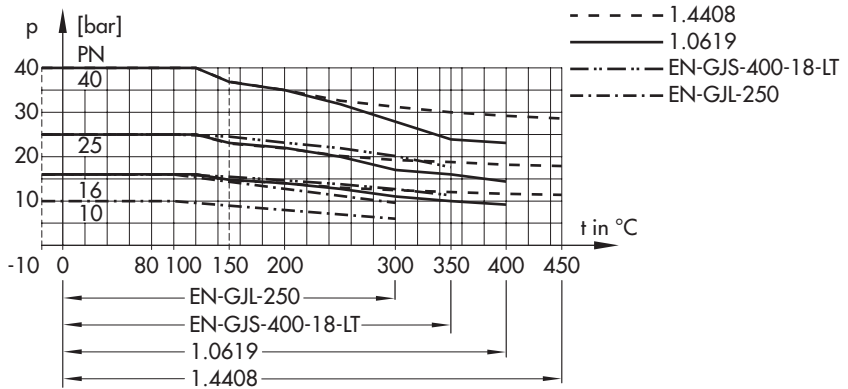

Fig. 4: Pressure-temperature diagram

4 Measures for preparation

After receiving the shipment, proceed as follows:

1. Check the scope of delivery. Compare the shipment received with the delivery note.
2. Check the shipment for transportation damage. Report any damage to SAMSON and the forwarding agent (refer to delivery note).

4.1 Unpacking

Note

Do not remove the packaging until immediately before installation.

Proceed as follows to lift and install the strainer:

1. Remove the packaging from the strainer.
2. Dispose of the packaging in accordance with the valid regulations.

NOTICE

Risk of strainer damage due to foreign particles entering it.

The protective caps fitted on the strainer's inlet and outlet prevent foreign particles from entering the strainer and damaging it.

Do not remove the protective caps until immediately before installation.

4.2 Transporting and lifting

DANGER

Danger due to suspended loads falling.
Stay clear of suspended or moving loads.

WARNING

Risk of lifting equipment tipping over and risk of damage to lifting accessories due to exceeding the rated lifting capacity.

- Only use approved lifting equipment and accessories whose minimum lifting capacity is higher than the weight of the strainer.
- Refer to Table 4 for weights.

WARNING

Risk of personal injury due to the strainer tipping.

- Observe the strainer's center of gravity.
- Secure the strainer against tipping over or turning.

Tip

- Our after-sales service can provide more detailed transport and lifting instructions on request.

4.2.1 Transporting

The strainer can be transported using lifting equipment (e.g. crane or forklift).

- ➔ Leave the strainer in its transport container or on the pallet to transport it.
- ➔ Observe the transport instructions.

Transport instructions

- Protect the strainer against external influences (e.g. impact).
- Do not damage the corrosion protection (paint, surface coatings). Repair any damage immediately.
- Protect the strainer against moisture and dirt.
- Observe the permissible ambient temperatures (see Chapter 3.1).

4.2.2 Lifting

To install a large strainer into the pipeline, use lifting equipment (e.g. crane or forklift) to lift it.

Lifting instructions

- Secure slings against slipping.
- Make sure the slings can be removed from the device once it has been installed into the pipeline.
- Prevent the strainer from tilting or tipping.
- Do not leave loads suspended when interrupting work for longer periods of time.

- Make sure that the axis of the pipeline is always horizontal during lifting and the axis of the plug stem is always vertical.

Version with flanges

1. Attach one sling to each flange of the body and to the rigging equipment (e.g. hook) of the crane or forklift (see Fig. 5).
2. Carefully lift the strainer. Check whether the lifting equipment and accessories can bear the weight.
3. Move the strainer at an even pace to the site of installation.
4. Install the strainer into the pipeline (see Chapter 5.3).
5. After installation in the pipeline, check whether the flanges are bolted tight and the strainer in the pipeline holds.
6. Remove slings.

Measures for preparation

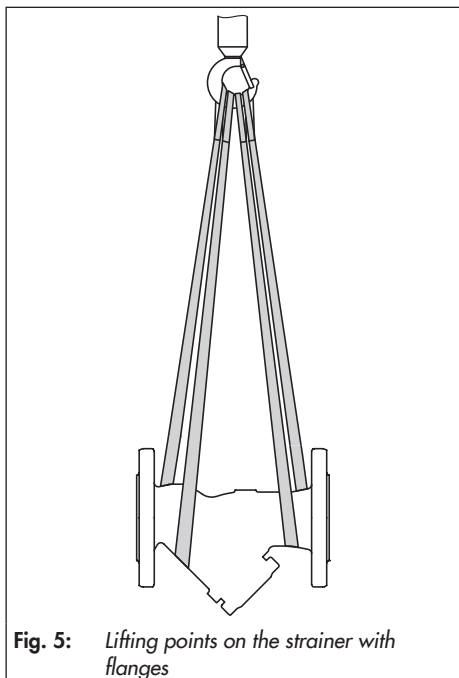

Fig. 5: Lifting points on the strainer with flanges

4. Move the strainer at an even pace to the site of installation.
5. Install the strainer into the pipeline (see Chapter 5.3).
6. After installation, check whether the weld seams hold.
7. Remove connectors and slings.



Tip

SAMSON recommends using a hook with safety latch (see Fig. 5 and Fig. 6). The safety latch prevents the slings from slipping during lifting and transporting.

Version with welding ends

1. Attach one sling to each welding end of the body and to the rigging equipment (e.g. hook) of the crane or forklift (see Fig. 6).
2. Secure the slings attached to the body against slipping using a connector.
3. Carefully lift the strainer. Check whether the lifting equipment and accessories can bear the weight.

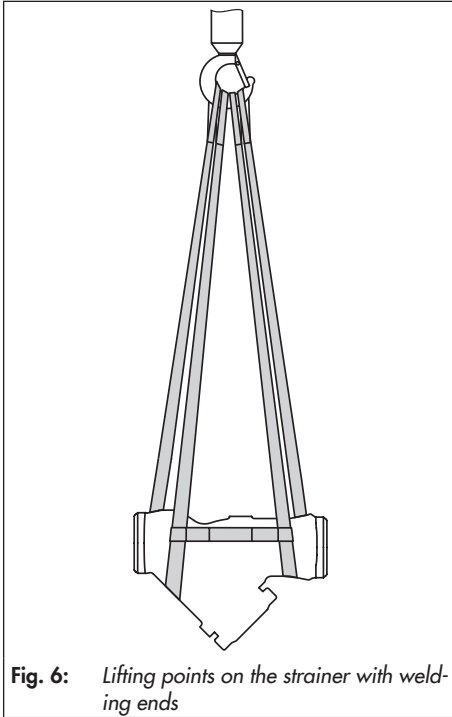

i Note

SAMSON recommends to regularly check the device and the prevailing storage conditions during long storage periods.

Storage instructions

- Protect the device against external influences (e.g. impact).
 - Do not damage the corrosion protection (paint, surface coatings). Repair any damage immediately.
 - Protect the device against moisture and dirt. Store it at a relative humidity of less than 75 %. In damp spaces, prevent condensation. If necessary, use a drying agent or heating.
 - Make sure that the ambient air is free of acids or other corrosive media.
 - Observe the permissible ambient temperatures (see Chapter 3.1).
 - Do not place any objects on the device.
-

💡 Tip

Our after-sales service can provide more detailed storage instructions on request.

4.3 Storage

🚫 NOTICE

Risk of strainer damage due to improper storage.

- Observe the storage instructions.
 - Avoid longer storage periods.
 - Contact SAMSON in case of different storage conditions or longer storage times.
-

4.4 Preparation for installation

Proceed as follows:

- Flush the pipelines.

i Note

The plant operator is responsible for cleaning the pipelines in the plant.

- Check the strainer to make sure that it is clean.
- Check the strainer for damage.
- Check to make sure that the type designation, nominal size, material, pressure rating and temperature range of the strainer match the plant conditions (size and pressure rating of the pipeline, medium temperature etc.).
- Check any mounted pressure gauges to make sure they function.

5 Mounting and start-up

! NOTICE

Risk of overheating due to excessive ambient temperatures or insufficient heat dissipation when components are insulated.

- *Do not include the strainer in the insulation of the pipeline.*
-

! NOTICE

Risk of impaired functioning of the strainer and leakage at the joint due to installation under tension.

- *Bolt the strainer to the pipeline free of stress.*
 - *If necessary, support the pipelines near the connections.*
 - *Do not attach supports directly to the strainer.*
-

5.1 Mounting positions

Horizontal pipelines

- **Gases and liquids**
Cover and filter face downwards.
- **Steam**
Cover and filter face sideward.

Vertical pipelines

- **Gases, vapors and liquids**
In strainers where the medium flows upward, the cover and filter face upward.

Installation conditions

- Make sure that the strainer remains freely accessible after the plant has been completed.
- Make sure the direction of flow matches the direction indicated by the arrow on the body.
- Allow sufficient space to remove the filter.
- Install the strainer free of stress.

NOTICE

Possible malfunction and damage due to adverse weather conditions (temperature, humidity).

- Do not install the device outdoors or in rooms prone to frost.
- Protect the strainer against frost if it is used in combination with freezing media.
- Either heat the strainer or remove it from the plant and completely drain the residual medium after a plant shutdown.

5.2 Additional fittings

Shut-off valve

Install a hand-operated shut-off valve both upstream and downstream of the strainer (see Fig. 7). This allows the plant to be shut down for cleaning and maintenance, and when the plant is not used for longer periods of time.

Pressure gauges

Install a pressure gauge both upstream and downstream of the strainer to monitor the pressures prevailing in the plant (see Fig. 7). Optionally with pressure gauge connections on the strainer body.

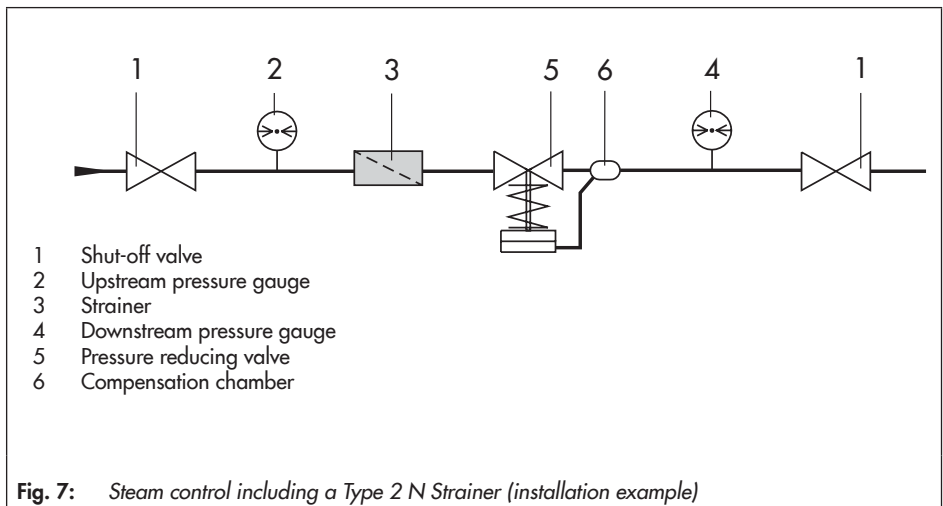

5.3 Installing the strainer

Version with flanges

1. Close the shut-off valve in the pipeline while the valve is being installed.
2. Remove the protective caps from the strainer ports before installing the strainer.
3. Lift the strainer using suitable lifting equipment to the site of installation (see Chapter 4.2). Observe the flow direction through the strainer. The arrow on the strainer indicates the direction of flow.
4. Make sure that the correct flange gaskets are used.
5. Bolt the pipeline to the strainer free of stress.
6. Depending on the field of application, allow the strainer to cool down or warm up to reach ambient temperature before start up.

Version with welding ends

1. Close the shut-off valve in the pipeline while the valve is being installed.
2. Lift the strainer using suitable lifting equipment to the site of installation (see Chapter 4.2). Observe the flow direction through the strainer. The arrow on the strainer indicates the direction of flow.
3. Weld the strainer free of stress into the pipeline.
4. Depending on the field of application, allow the strainer to cool down or warm

up to reach ambient temperature before start up.

5.4 Start-up

⚠ DANGER

Risk of personal injury due to process medium escaping.

- Do not start up the strainer until all parts have been mounted.
-

ⓘ NOTICE

Risk of the body bursting due to excessive pressure during pressure testing.

- The pressure must not exceed the maximum permissible pressure by 1.5 times the pressure rating.
-

ⓘ NOTICE

Risk of the strainer being destroyed by steam hammering.

- Drain off any condensate in the pipeline.
 - Vent the plant.
-

ⓘ NOTICE

Risk of strainer damage due to a sudden pressure increase and resulting high flow velocities.

- Slowly open the shut-off valve in the pipeline during start-up.
-

Once installed in the pipeline, the strainer can be put into operation.

5.4.1 Gases and liquids

- Open the shut-off valves slowly preferably starting from the upstream pressure side.
- Avoid pressure surges.

5.4.2 Steam

- Completely drain and dry steam lines to prevent water hammering.
- Slowly allow the steam to enter the plant to ensure that the pipes and valves warm up evenly and to avoid excessive flow velocities.
- Before the full capacity is reached, drain off the start-up condensate.
- Make sure that the air contained in the plant escapes as quickly as possible.
- Open the shut-off valves slowly preferably starting from the upstream pressure side.
- Avoid pressure surges.

6 Servicing

The strainer does not require much maintenance. Nevertheless, it is subject to natural wear, particularly at the filter. Depending on the operating conditions, check the strainer at regular intervals to avoid possible malfunctions.

⚠ DANGER

Risk of bursting in pressure equipment.
Strainers and pipelines are pressure equipment. Improper opening can lead to bursting of the strainer.

- Before starting any work on the strainer, depressurize all plant sections affected as well as the strainer.
- Drain the process medium from all the plant sections affected as well as from the strainer.
- Wear personal protective equipment.

⚠ WARNING

Risk of personal injury due to residual process medium in the strainer.
While working on the strainer, residual process medium can escape and, depending on its properties, may lead to personal injury, e.g. (chemical) burns.

Wear protective clothing, safety gloves and eye protection.

⚠ WARNING

Risk of burn injuries due to hot or cold components and pipeline.
The strainer and pipeline may become very hot or cold. Risk of burn injuries.

- Allow components and pipelines to cool down or warm up to the ambient temperature.
- Wear protective clothing and safety gloves.

NOTICE

Risk of strainer damage due to incorrect service or repair.

Only allow trained staff to perform service and repair work.

NOTICE

Risk of strainer damage due to over- or under-torquing.

Observe the specified torques when tightening strainer components. Excessive tightening torques lead to parts wearing out more quickly. Parts that are too loose may cause leakage.

Observe the specified tightening torques (see Chapter 9.2).

NOTICE

Risk of strainer damage due to the use of unsuitable lubricants.

Only use lubricants approved by SAMSON (see Chapter 9.2).

Note

The strainer was checked by SAMSON before delivery.

- Certain test results certified by SAMSON lose their validity when the strainer is opened. Such testing includes leak tests.
 - The product warranty becomes void if service or repair work not described in these instructions is performed without prior agreement by SAMSON's After-sales Service.
 - Only use original spare parts by SAMSON, which comply with the original specifications.
-

Tip

SAMSON's After-sales Service can support you in drawing up an inspection and test plan for your plant.

6.1 Cleaning or exchanging the filter

→ See Fig. 2

ⓘ NOTICE

Risk of strainer damage due to over- or under-torquing.

Observe the specified torques when tightening strainer components. Excessive tightening torques lead to parts wearing out more quickly. Parts that are too loose may cause leakage.

Observe the specified tightening torques (see Chapter 9.2).

Removal

1. Put the plant out of operation (see Chapter 8.1).
2. Remove the cover (4) by unscrewing the cover nuts. See Chapter 9.2 for size of the open-end wrench.
3. Remove filter (2) and seal (3).
4. Thoroughly clean the filter.
Replace a damaged filter.

Installation

1. Renew the seal (3) (see Chapter 9.2) and insert the new seal in the cover (4).
2. Insert the filter (2) into the cover (4).
3. Mount the cover (4) by screwing on the cover nuts. Observe the tightening torques specified in Chapter 9.2.
4. Put the plant into operation (see Chapter 5.4).

6.2 Preparation for return shipment

Defective strainers can be returned to SAMSON for repair. Proceed as follows to return devices to SAMSON:

1. Put the plant out of operation (see Chapter 8.1).
2. Decontaminate the strainer. Remove any residual process medium.
3. Fill in the Declaration on Contamination. The declaration form can be downloaded from our website at
▶ www.samsongroup.com > SERVICE > After Sales Service.
4. Continue as described on our website at
▶ www.samsongroup.com > SERVICE > After-sales Service > Returning goods.

6.3 Ordering spare parts and operating supplies

Contact your nearest SAMSON subsidiary or SAMSON's After-sales Service for information on spare parts, lubricants and tools.

Spare parts

See Chapter 9.2 for details on spare parts.

Lubricants

See Chapter 9.2 for details on suitable lubricants.

Tools

Contact SAMSON's After-sales Service for more information on tools.

7 Malfunctions

The malfunctions listed in Table 5 are caused by mechanical faults and incorrect strainer sizing. In the simplest case, the functioning can be restored following the recommended action. Special tools may be required for repair work.

For troubleshooting, the conditions, such as installation, process medium, temperature and pressure conditions, must be taken into account.

SAMSON's After-sales Service can help during troubleshooting. Further information is available in Chapter 9.1.



Tip

SAMSON's After-sales Service can support you in drawing up an inspection and test plan for your plant.



Note

Contact SAMSON's After-sales Service for malfunctions not listed in the table.

7.1 Emergency action

Plant operators are responsible for emergency action to be taken in the plant.

SAMSON recommends removing the strainer from the pipeline before repairing it.

In the event of a strainer malfunction:

1. Close the shut-off valves upstream and downstream of the strainer to stop the process medium from flowing through the strainer.
2. Perform troubleshooting (see Table 5).
3. Rectify those malfunctions that can be remedied following the information given in this document. Contact SAMSON's After-sales Service in all other cases.

Putting the device back into operation after a malfunction

See the 'Start-up' chapter.

Table 5: Troubleshooting

Malfunction	Possible reasons	Recommended action
Pressure drops below the adjusted set point of the pressure regulator installed downstream.	Strainer installed against the flow.	<ul style="list-style-type: none"> ➔ Install the strainer so that the direction of flow matches the direction indicated by the arrow on the body. ➔ Check the filter for deformation. Replace the filter, if necessary.
	Foreign particles and dirt blocking the filter.	<ul style="list-style-type: none"> ➔ Remove foreign particles and dirt. ➔ Replace a damaged filter.
	Strainer or K_{VS}/C_V coefficient too small.	<ul style="list-style-type: none"> ➔ Check the sizing. ➔ Install the correctly sized strainer.
Loud noises.	High flow velocity, cavitation.	<ul style="list-style-type: none"> ➔ Check the sizing. ➔ If necessary, install a larger strainer. ➔ Check the filter for deformation. Replace the filter, if necessary.
Leakage at the strainer.	The seal is defective.	➔ Replace damaged parts.

8 Decommissioning and removal

⚠ DANGER

Risk of bursting in pressure equipment.

Strainers and pipelines are pressure equipment. Improper opening can lead to bursting of the strainer.

- Before starting any work on the strainer, depressurize all plant sections affected as well as the strainer.
- Drain the process medium from all the plant sections affected as well as from the strainer.
- Wear personal protective equipment.

⚠ WARNING

Risk of burn injuries due to hot or cold components and pipeline.

The strainer and pipeline may become very hot or cold. Risk of burn injuries.

- Allow components and pipelines to cool down or warm up to the ambient temperature.
- Wear protective clothing and safety gloves.

⚠ WARNING

Risk of personal injury due to residual process medium in the strainer.

While working on the strainer, residual process medium can escape and, depending on its properties, may lead to personal injury, e.g. (chemical) burns.

Wear protective clothing, safety gloves and eye protection.

Decommissioning and removal

8.1 Decommissioning

To decommission the strainer for service and repair work or disassembly, proceed as follows:

1. Close the shut-off valve on the upstream side.
2. Close the shut-off valve on the downstream side.
3. Depressurize the plant.
4. If necessary, allow the pipeline and strainer to cool down or warm up to the ambient temperature.
5. Completely drain the pipelines and strainer.
6. Remove the strainer from the pipeline (see Chapter 4.2).

8.2 Disposal

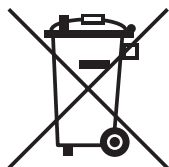

SAMSON is a producer registered in Europe, agency in charge
▶ <https://www.samsongroup.com/en/about-samson/environment-social-governance/material-compliance/waste-electrical-and-electronic-equipment-weee-and-its-safe-disposal/>.
WEEE reg. no.: DE 62194439

Information on substances listed as substances of very high concern (SVHC) on the candidate list of the REACH regulation can be found in the document "Additional Information on Your Inquiry/Order", which is added to the order documents, if applicable. This document includes the SCIP number assigned to the devices concerned. This num-

ber can be entered into the database on the European Chemicals Agency (ECHA) website (▶ <https://www.echa.europa.eu/scip-database>) to find out more information on the SVHC contained in the device.

i Note

SAMSON can provide you with a recycling passport on request. Simply e-mail us at aftersaleservice@samsongroup.com giving details of your company address.

💡 Tip

On request, SAMSON can appoint a service provider to dismantle and recycle the product as part of a distributor take-back scheme.

-
- ➔ Observe local, national and international refuse regulations.
 - ➔ Do not dispose of components together with your other household waste.

9 Appendix

9.1 After-sales service

Contact SAMSON's After-sales Service for support concerning service or repair work or when malfunctions or defects arise.

E-mail address

You can reach our after-sales service at aftersaleservice@samsongroup.com.

Addresses of SAMSON AG and its subsidiaries

The addresses of SAMSON, its subsidiaries, representatives and service facilities worldwide can be found on our website (▶ www.samsongroup.com) or in all SAMSON product catalogs.

To assist diagnosis and in case of an unclear mounting situation, specify the following details (so far as possible). See Chapter 2:

- Device type and nominal size
- Upstream and downstream pressure
- Temperature and process medium
- Max. flow rate
- Installation drawing showing the exact location of the strainer and all the additionally installed components (shut-off valves, pressure gauge etc.)

9.2 Spare parts, tightening torques and lubricant

Table 6: *Tightening torque of cover nuts*

Nominal size	Quantity of cover nuts	Size of cover nuts	Width across flats of cover nuts	Tightening torque
DN 15	2 pieces	M10	16 (17)	~30 Nm
DN 20				
DN 25				
DN 32				
DN 40				
DN 50	4 pieces	M12	18 (19)	~50 Nm
DN 65		M16	24	~100 Nm
DN 80				
DN 100				
DN 125				
DN 150				
DN 200	6 pieces	M20	30	~170 Nm
DN 250	8 pieces			
	10 pieces			

Table 7: *Order numbers for filter and seal*

Nominal size	Type 2 N (standard strainer insert)	Type 2 NI (dual strainer insert)	Gasket
	Order no.		
	0550 -	0550 -	8422 -
DN 15	0222	0238	0011
DN 20	0223	0239	0019
DN 25	0224	0240	0023
DN 32	0225	0241	0029
DN 40	0226	0242	0039
DN 50	0227	0243	0048
DN 65	0228	0244	0056
DN 80	0229	0245	0065
DN 100	0230	0246	0076
DN 125	0231	0247	0084
DN 150	0232	0248	0092
DN 200	0233	0249	0102
DN 250	0234	0250	8414 - 1510

Table 8: *Recommended lubricant*

Designation	Temperature range in °C	Color	Packs in g	Item no. of lubricant
Gleitmo 1763 V	-20 to +1000	Gray	5000	8150-0119
			250	8150-4008
			100	8150-4010

9.3 Certificates

The EU declarations of conformity are included on the next pages.

EU DECLARATION OF CONFORMITY TRANSLATION



Module A

For the following products, SAMSON hereby declares under its sole responsibility:

Devices	Series	Type	Version	
Self-operated Regulators	43	2432	DIN EN, body, CC499K and EN-GJS-400-18-LT, DN 50, PN 25, fluids G2, L2, L1 ¹⁾	
	43	2436	DIN EN, body, CC499K and EN-GJS-400-18-LT, DN 50, PN 25, fluids G2, L2, L1 ¹⁾	
	43	2437	DIN EN, body, CC499K and EN-GJS-400-18-LT, DN 50, PN 25, fluids G2, L2, L1 ¹⁾	
Self-operated Regulators	---	2111	DIN EN, body, EN-GJS-400-18-LT, DN 50, PN 25, fluids G2, L2, L1 ¹⁾ DIN EN, body, 1.0619 and 1.4408, DN 40-50, PN 40, fluids G2, L2, L1 ¹⁾ ANSI, body, A216 WCC and A351 CF8M, NPS 1½-2, Class 300, fluids G2, L2, L1 ¹⁾	
	Three-way valve	---	2119	DIN EN, body, EN-GJL-250 and 1.0619, DN 65-125, PN 16, fluids G2, L2, L1 ¹⁾ DIN EN, body, 1.0619, DN 50-80, PN 25, fluids G2, L2, L1 ¹⁾ DIN EN, body, 1.0619 and 1.4408, DN 40-50, PN 40, fluids G2, L2, L1 ¹⁾ ANSI, body, A216 WCC and A351 CF8M, NPS 2½-4, Class 150, fluids G2, L2, L1 ¹⁾ ANSI, body, A216 WCC and A351 CF8M, NPS 1½, Class 300, fluids G2, L2, L1 ¹⁾
				Control valve
Three-way valve	---	3226	DIN EN, body, CC499K, DN 50, PN 25, fluids G2, L2 ²⁾	
Three-way valve	---	3260	DIN EN, body, EN-GJL-250, DN 65-200, PN 16, fluids G2, L2 ²⁾	
Globe valve Three-way valve	V2001	3531	DIN EN, body, EN-GJS-400-18-LT, DN 50-80, PN 25, fluids G2, L2, L1 ¹⁾	
		3535	DIN EN, body, 1.0619 and 1.4408, DN 32-40, PN 25, all fluids ANSI, body, A216 WCC and A351 CF8M, NPS 1½-2, Class 150, all fluids	
Control valve	---	3214	DIN EN, body, EN-GJL-250, DN 65-125, PN 16, fluids G2, L2, L1 ¹⁾ DIN EN, body, EN-GJS-400-18-LT, DN 50-80, PN 25, fluids G2, L2, L1 ¹⁾ ANSI, body, A126 B, NPS 3-4, Class 125, fluids G2, L2, L1 ¹⁾ ANSI, body, A216 WCC and A351 CF8M, NPS 1½-2, Class 150, all fluids	
			Self-operated Regulators	42
Self-operated Regulators	42	2422		
			Strainers	1N/1NI
Strainers	2N/2NI	2602	DIN EN, body, EN-GJL-250, DN 200-250, PN 10, fluids G2, L2, L1 ¹⁾ DIN EN, body, EN-GJL-250, DN 65-125, PN 16, fluids G2, L2, L1 ¹⁾ DIN EN, body, EN-GJS-400-18-LT, DN 100-125, PN 16, fluids G2, L2, L1 ¹⁾ DIN EN, body, EN-GJS-400-18-LT, DN 50-80, PN 25, fluids G2, L2, L1 ¹⁾ DIN EN, body, 1.4408, DN 32-50, PN 16, all fluids	
			Self-operated Regulators	44
Self-operated Regulators	44	2440 (44-0B) 2441 (44-1B) 2446 (44-5B)		
			Self-operated Regulators	44

Revision 01

Classification: Public · SAMSON AKTIENGESELLSCHAFT · Weismuellerstrasse 3 · 60314 Frankfurt am Main, Germany

Page 1 of 3

EU DECLARATION OF CONFORMITY TRANSLATION



Devices	Series	Type	Version
Self-operated Regulators	45	2451 (45-1)	DIN EN, body, EN-GJS-400-18-LT and CC499K, DN 50, PN 25, fluids G2, L2, L1 ¹⁾
		2452 (45-2)	
		2453 (45-3)	
		2454 (45-4)	
		2456 (45-6)	
	46	2465 (46-5)	DIN EN, body, EN-GJS-400-18-LT and CC499K, DN 50, PN 25, fluids G2, L2, L1 ¹⁾
		2466 (46-6)	
		2467 (46-7)	
		2469 (46-9)	
	47	2471 (47-1)	DIN EN, body, EN-GJS-400-18-LT and CC499K, DN 50, PN 25, fluids G2, L2, L1 ¹⁾
		2474 (47-4)	
		2475 (47-5)	
		2479 (47-9)	
	48	2488	DIN EN, body, EN-GJS-400-18-LT and CC499K, DN 50, PN 25, fluids G2, L2, L1 ¹⁾
		2489	
	40	2405	DIN EN, body, EN-GJS-400-18-LT, DN 50, PN 25, fluids G2, L2, L1 ¹⁾
			ANSI, body, A216 WCC and A351 CF8M, NPS 1½-2, Class 150, all fluids
		2406	DIN EN, body, EN-GJL-250, DN 65-125, PN 16, fluids G2, L2, L1 ¹⁾
			DIN EN, body, EN-GJS-400-18-LT, DN 50, PN 25, fluids G2, L2, L1 ¹⁾
			ANSI, body, A126 B, NPS 3-4, Class 125, fluids G2, L2, L1 ¹⁾
			ANSI, body, A216 WCC and A351 CF8M, NPS 1½-2, Class 150, all fluids
	41	2412 2417	DIN EN, body, EN-GJL-250, DN 65-100, PN 16, fluids G2, L2, L1 ¹⁾
			DIN EN, body, EN-GJS-400-18-LT, DN 50-80, PN 25, fluids G2, L2, L1 ¹⁾
	42	2421 RS	ANSI, body, A126 B, NPS 3-4, Class 125, fluids G2, L2, L1 ¹⁾
			DIN EN, body, A216 WCC and A351 CF8M, NPS 1½-2, Class 150, all fluids
			DIN EN, body, 1.0619, 1.4408, 1.4571 and 1.4401/1.4404, DN 32-50, PN 16, all fluids
			DIN EN, body, 1.0619, 1.4408, 1.4571 and 1.4401/1.4404, DN 32-40, PN 25, all fluids
			ANSI, body, A216 WCC, A351 CF8M and A182 F316/A182 F316L, NPS 1½-2, Class 150, all fluids
	---	2331	DIN EN, body, EN-GJL-250, DN 65-200, PN 16, fluids G2, L2 ²⁾
			DIN EN, body, EN-GJS-400-18-LT, DN 65-150, PN 16, fluids G2, L2 ²⁾
DIN EN, body, EN-GJS-400-18-LT, DN 65-125, PN 25, fluids G2, L2 ²⁾			
DIN EN, body, 1.0619, DN 65-200, PN 16, fluids G2, L2 ²⁾			
---	2337	DIN EN, body 1.0619, DN 65-100, PN 40, fluids G2, L2 ²⁾	
		DIN EN, body 1.0619, DN 250, PN 25, fluids L1 ¹⁾	
---	2333 2335	DIN EN, body 1.0619, DN 250, PN 40, fluids L1 ¹⁾	
		DIN EN, body, EN-GJL-250, DN 65-125, PN 16, fluids G2, L2, L1 ¹⁾	
---	2334	DIN EN, body, EN-GJS-400-18-LT, DN 65-80, PN 25, fluids G2, L2, L1 ¹⁾	
		DIN EN, body, EN-GJS-400-18-LT, DN 65-80, PN 25, fluids G2, L2, L1 ¹⁾	
		DIN EN, body, EN-GJS-400-18-LT, DN 65-80, PN 25, fluids G2, L2, L1 ¹⁾	
		ANSI, body, A126 B, NPS 3-4, Class 125, fluids G2, L2, L1 ¹⁾	
---	2404-1	DIN EN, body, EN-GJL-250, DN 65-125, PN16, fluids G2, L2, L1 ¹⁾	
		ANSI, body, A126 B, NPS 3-4, Class 125, fluids G2, L2, L1 ¹⁾	
---	2404-2	DIN EN, body, A216 WCC and A351 CF8M, NPS 1½-2, Class 150, all fluids	
		DIN EN, body, EN-GJL-250, DN 65-125, PN 16, fluids G2, L2, L1 ¹⁾	
			ANSI, body, A126 B, NPS 3-4, Class 125, fluids G2, L2, L1 ¹⁾

¹⁾ Gases according to Article 4(1)(c.i), second indent
Liquids according to Article 4(1)(c.ii)

²⁾ Gases according to Article 4(1)(c.i), second indent
Liquids according to Article 4(1)(c.ii), second indent

Revision 01

EU DECLARATION OF CONFORMITY
TRANSLATION



That the products mentioned above comply with the requirements of the following standards:

Directive of the European Parliament and of the Council on the harmonization of the laws of the Member States relating to the making available on the market of pressure equipment	2014/68/EU	of 15. May 2014
Applied conformity assessment procedure for fluids according to Article 4(1)	Module A	

Technical standards applied: DIN EN 12516-2, DIN EN 12516-3, ASME B16.34

Manufacturer: SAMSON AG, Weismüllerstraße 3, 60314 Frankfurt am Main, Germany

Frankfurt am Main, 05. June 2024

ppc. Norbert Tollas
Senior Vice President
Global Operations

i.V. Peter Scheermesser
Director
Product Maintenance & Engineered Products

Revision 01

Classification: Public · SAMSON AKTIENGESELLSCHAFT · Weismuellerstrasse 3 · 60314 Frankfurt am Main, Germany

Page 3 of 3

EU DECLARATION OF CONFORMITY TRANSLATION



Module H / N° CE-0062-PED-H-SAM 001-22-DEU-rev-A

For the following products, SAMSON hereby declares under its sole responsibility:

Devices	Series	Type	Version
Three-way valve	---	2119	DIN EN, body, EN-GJL-250 and 1.0619, DN 150, PN 16, fluids G2, L2, L1 ¹⁾
			DIN EN, body, 1.0619, DN 100-150, PN 25, fluids G2, L2, L1 ¹⁾
			DIN EN, body, 1.0619 and 1.4408, DN 65-150, PN 40, fluids G2, L2, L1 ¹⁾
			ANSI, body, A216 WCC and A351 CF8M, NPS 6, Class 150, fluids G2, L2, L1 ¹⁾
			ANSI, body, A216 WCC and A351 CF8M, NPS 2-6, Class 300, fluids G2, L2, L1 ¹⁾
Self-operated Regulators	---	3222	DIN EN, body, CC499K, DN 50, PN 25, all fluids
Three-way valve	---	3260	DIN EN, body, EN-GJL-250, DN 250-300, PN 16, fluids G2, L2 ¹⁾
Globe valve Three-way valve	V2001	3531	DIN EN, body, 1.0619 and 1.4408, DN 50-80, PN 25, all fluids
		3535	ANSI, body, A216 WCC and A351 CF8M, NPS 2½-3, Class 150, all fluids
Control valve	---	3214	DIN EN, body, EN-GJL-250, DN 150-400, PN 16, fluids G2, L2, L1 ¹⁾
			DIN EN, body, EN-GJS-400-18-LT, DN 100-150, PN 25, fluids G2, L2, L1 ¹⁾
			DIN EN, body, 1.0619, DN 32-400, PN 40, all fluids
			ANSI, body, A126 B, NPS 6-10, Class 125, fluids G2, L2, L1 ¹⁾
			ANSI, body, A216 WCC, NPS 2½-10, Class 150, all fluids
			ANSI, body, A216 WCC, NPS 1½-10, Class 300, all fluids
Self-operated Regulators	42	2423	DIN EN, body, EN-GJL-250, DN 150-250, PN 16, fluids G2, L2, L1 ¹⁾
			DIN EN, body, EN-GJS-400-18-LT, DN 150, PN 16, fluids G2, L2, L1 ¹⁾
			DIN EN, body, EN-GJS-400-18-LT, DN 100-150, PN 25, fluids G2, L2, L1 ¹⁾
			DIN EN, body, 1.0619 and 1.4408, DN 65-250, PN 16, all fluids
			DIN EN, body, 1.0619 and 1.4408, DN 50-250, PN 25, all fluids
			DIN EN, body, 1.0619 and 1.4408, DN 32-250, PN 40, all fluids
			ANSI, body, A126 B, NPS 6-10, Class 125, fluids G2, L2, L1 ¹⁾
			ANSI, body, A216 WCC and A351 CF8M, NPS 2½-10, Class 150, all fluids
			ANSI, body, A216 WCC and A351 CF8M, NPS 1½-10, Class 300, all fluids
			DIN EN, body, EN-GJL-250, DN 150-400, PN 16, fluids G2, L2, L1 ¹⁾
			DIN EN, body, EN-GJS-400-18-LT, DN 100-150, PN 25, fluids G2, L2, L1 ¹⁾
			DIN EN, body, 1.0619 and 1.4408, DN 65-400, PN 16, all fluids
	DIN EN, body, 1.0619 and 1.4408, DN 200-400, PN 25, all fluids		
	DIN EN, body, 1.0619 and 1.4408, DN 32-400, PN 40, all fluids		
	DIN EN, body, 1.0460, DN 40-50, PN 40, all Fluids		
	DIN EN, body, 1.6220+QT, DN 65-250, PN 16, all fluids		
	DIN EN, body, 1.6220+QT, DN 200-250, PN 25, all fluids		
	DIN EN, body, 1.6220+QT, DN 32-250, PN 40, all fluids		
	ANSI, body, A126 B, NPS 6-16, Class 125, fluids G2, L2, L1 ¹⁾		
	ANSI, body, A216 WCC and A351CF8M, NPS 2½-16, Class 150, all fluids		
	ANSI, body, A216 WCC and A351CF8M, NPS 1½-16, Class 300, all fluids		
	ANSI, body, A105, NPS 1½-2, Class 300, all fluids		
	ANSI, body, A352 LCC, NPS 2½-10, Class 150, all fluids		
	ANSI, body, A352 LCC, NPS 1½-10, Class 300, all fluids		
	DIN EN, body, 1.0619 and 1.4408, DN 65-150, PN 16, all fluids		
	DIN EN, body, 1.0619 and 1.4408, DN 50-150, PN 25, all fluids		
	DIN EN, body, 1.0619 and 1.4408, DN 32-150, PN 40, all fluids		
	DIN EN, body, 1.4571 and 1.4401/1.4404, DN 50, PN 25, all fluids		
	DIN EN, body, 1.4571 and 1.4401/1.4404, DN 32-50, PN 40, all fluids		
	ANSI, body, A216 WCC and A351 CF8M, NPS 2½-6, Class 150, all fluids		
ANSI, body, A216 WCC and A351 CF8M, NPS 1½-6, Class 300, all fluids			
42	2421RS	DIN EN, body, 1.0619 and 1.4408, DN 65-150, PN 16, all fluids	
DIN EN, body, 1.0619 and 1.4408, DN 50-150, PN 25, all fluids			
DIN EN, body, 1.0619 and 1.4408, DN 32-150, PN 40, all fluids			
DIN EN, body, 1.4571 and 1.4401/1.4404, DN 50, PN 25, all fluids			
DIN EN, body, 1.4571 and 1.4401/1.4404, DN 32-50, PN 40, all fluids			
ANSI, body, A216 WCC and A351 CF8M, NPS 2½-6, Class 150, all fluids			
ANSI, body, A216 WCC and A351 CF8M, NPS 1½-6, Class 300, all fluids			

Revision 01

Classification: Public · SAMSON AKTIENGESELLSCHAFT · Weismüllerstrasse 3 · 60314 Frankfurt am Main, Germany

Page 1 of 3

EU DECLARATION OF CONFORMITY TRANSLATION



Devices	Series	Type	Version	
Self-operated Regulators	40	2405	DIN EN, body, 1.0619, 1.4571, 1.4404, 1.4408, 1.0460, DN 32-50, PN40, all fluids	
			ANSI, body, A105, A182 F316L, A351 CF8M, A216 WCC, NPS 1½-2, Class 300, all fluids	
		2406	DIN EN, body, EN-GJL-250, DN 150, PN 16, fluids G2, L2, L1 ¹⁾	
			DIN EN, body, 1.0619 and 1.4408, DN 32-150, PN 40, all fluids	
			DIN EN, body, 1.0460 and 1.4404, DN 32-50, PN 40, all fluids	
			ANSI, body, A126 B, NPS 6, Class 125, fluids G2, L2, L1 ¹⁾	
			ANSI, body, A216 WCC and A351 CF8M, NPS 2½-6, Class 150, all fluids	
			ANSI, body, A216 WCC and A351 CF8M, NPS 1½-6, Class 300, all fluids	
			ANSI, body, A105 and A182 F316L, NPS 1½-2, Class 300, all fluids	
			DIN EN, body, EN-GJS-400-18-LT, DN 100, PN25, fluids G2, L2, L1 ¹⁾	
		41	2412 2417	DIN EN, body, 1.0619 and 1.4408, DN 32-100, PN 40, all fluids
				DIN EN, body, 1.0460, 1.4571 and 1.4404, DN 32-80, PN 40, all fluids
	ANSI, body, A216 WCC and A351 CF8M, NPS 2½-4, Class 150, all fluids			
	ANSI, body, A216 WCC and A351 CF8M, NPS 1½-4, Class 300, all fluids			
	ANSI, body, A105 and A182 F316L, NPS 1½-3, Class 300, all fluids			
	---		2404-1	DIN EN, body, EN-GJL-250, DN 150, PN16, fluids G2, L2, L1 ¹⁾
	DIN EN, body, 1.0619 und 1.4408, DN 32-150, PN 40, all fluids			
	2404-2	---	ANSI, body, A126 B, NPS 6, Class 125, fluids G2, L2, L1 ¹⁾	
			ANSI, body, A216 WCC und A351 CF8M, NPS 2½-6, Class 150, all fluids	
			ANSI, body, A216 WCC und A351 CF8M, NPS 1½-6, Class 300, all fluids	
			DIN EN, body, EN-GJL-250, DN 150-400, PN 16, fluids G2, L2, L1 ¹⁾	
			DIN EN, body, 1.0619 und 1.4408, DN 65-400, PN 16, all fluids	
			DIN EN, body, 1.0619 und 1.4408, DN 65-400, PN 40, all fluids	
		---	ANSI, body, A126 B, NPS 6-16, Class 125, fluids G2, L2, L1 ¹⁾	
			ANSI, body, A216 WCC und A351 CF8M, NPS 2½-16, Class 150, all fluids	
			ANSI, body, A216 WCC und A351 CF8M, NPS 2½-10, Class 300, all fluids	
			DIN EN, body, EN-GJL-250, DN 250, PN 16, fluids G2, L2 ²⁾	
			DIN EN, body, 1.0619, DN 250, PN 16, fluids G2, L2 ²⁾	
			DIN EN, body, 1.0619, DN 200-250, PN 25, fluids G2, L2 ²⁾	
	2331	---	DIN EN, body, EN-GJL-250, DN 150-400, PN 16, fluids G2, L2, L1 ¹⁾	
			DIN EN, body, EN-GJS-400-18-LT, DN 100-150, PN 25, fluids G2, L2, L1 ¹⁾	
			DIN EN, body, 1.0619 und 1.4408, DN 65-400, PN 16, all fluids	
			DIN EN, body, 1.0619 und 1.4408, DN 200-400, PN 25, all fluids	
			DIN EN, body, 1.0619 und 1.4408, DN 65-400, PN 40, all fluids	
			ANSI, body, A126 B, NPS 6-16, Class 125, fluids G2, L2, L1 ¹⁾	
		---	ANSI, body, A216 WCC und A351 CF8M, NPS 2½-16, Class 150, all fluids	
			ANSI, body, A216 WCC und A351 CF8M, NPS 2½-16, Class 300, all fluids	
			DIN EN, body, EN-GJL-250, DN 150-400, PN 16, fluids G2, L2, L1 ¹⁾	
			DIN EN, body, EN-GJS-400-18-LT, DN 150, PN 16, fluids G2, L2, L1 ¹⁾	
			DIN EN, body, EN-GJS-400-18-LT, DN 100-150, PN 25, fluids G2, L2, L1 ¹⁾	
			DIN EN, body, 1.0619 und 1.4408, DN 65-400, PN 16, all fluids	
	2333 2335	---	DIN EN, body, 1.0619 und 1.4408, DN 200-400, PN 25, all fluids	
DIN EN, body, 1.0619 und 1.4408, DN 65-400, PN 40, all fluids				
ANSI, body, A126 B, NPS 6-16, Class 125, fluids G2, L2, L1 ¹⁾				
ANSI, body, A216 WCC und A351 CF8M, NPS 2½-16, Class 150, all fluids				
ANSI, body, A216 WCC und A351 CF8M, NPS 2½-16, Class 300, all fluids				
DIN EN, body, EN-GJL-250, DN 150-400, PN 16, fluids G2, L2, L1 ¹⁾				
---		DIN EN, body, EN-GJS-400-18-LT, DN 150, PN 16, fluids G2, L2, L1 ¹⁾		
		DIN EN, body, EN-GJS-400-18-LT, DN 100-150, PN 25, fluids G2, L2, L1 ¹⁾		
		DIN EN, body, 1.0619 und 1.4408, DN 65-400, PN 16, all fluids		
		DIN EN, body, 1.0619 und 1.4408, DN 200-400, PN 25, all fluids		
		DIN EN, body, 1.0619 und 1.4408, DN 65-400, PN 40, all fluids		
		ANSI, body, A126 B, NPS 6-16, Class 125, fluids G2, L2, L1 ¹⁾		
2334	---	ANSI, body, A216 WCC und A351 CF8M, NPS 2½-16, Class 150, all fluids		
		ANSI, body, A216 WCC und A351 CF8M, NPS 2½-16, Class 300, all fluids		
		DIN EN, body, EN-GJL-250, DN 150-400, PN 16, fluids G2, L2, L1 ¹⁾		
		DIN EN, body, EN-GJS-400-18-LT, DN 150, PN 16, fluids G2, L2, L1 ¹⁾		
		DIN EN, body, EN-GJS-400-18-LT, DN 100-150, PN 25, fluids G2, L2, L1 ¹⁾		
		DIN EN, body, 1.0619 und 1.4408, DN 65-400, PN 16, all fluids		
	---	DIN EN, body, 1.0619 und 1.4408, DN 200-400, PN 25, all fluids		
		DIN EN, body, 1.0619 und 1.4408, DN 65-400, PN 40, all fluids		
		ANSI, body, A126 B, NPS 6-16, Class 125, fluids G2, L2, L1 ¹⁾		
		ANSI, body, A216 WCC und A351 CF8M, NPS 2½-16, Class 150, all fluids		
		ANSI, body, A216 WCC und A351 CF8M, NPS 2½-16, Class 300, all fluids		
		DIN EN, body, 1.4469 and 1.4470, DN 32-50, PN 40, all fluids		
2373 2375	---	ANSI, body, A995 5A and A995 4A, NPS 1½-2, Class 300, all fluids		
		DIN EN, body, EN-GJL-250, DN 150-250, PN 16, fluids G2, L2, L1 ¹⁾		
Strainers	2N/2NI	2602	DIN EN, body, EN-GJS-400-18-LT, DN 150, PN 16, fluids G2, L2, L1 ¹⁾	
			DIN EN, body, EN-GJS-400-18-LT, DN 100-150, PN 25, fluids G2, L2, L1 ¹⁾	
			DIN EN, body, EN-GJS-400-18-LT, DN 100-150, PN 25, fluids G2, L2, L1 ¹⁾	
			DIN EN, body, 1.0619, DN 100-250, PN 16, all fluids	

Revision 01

Classification: Public · SAMSON AKTIENGESELLSCHAFT · Weismuellerstrasse 3 · 60314 Frankfurt am Main, Germany

Page 2 of 3

EU DECLARATION OF CONFORMITY TRANSLATION



Devices	Series	Type	Version
Strainers	2N/2NI	2602	DIN EN, body, 1.0619, DN 200-250, PN 25, all fluids
			DIN EN, body, 1.0619, DN 32-250, PN 40, all fluids
			DIN EN, body, 1.4408, DN 65-100, PN 16, all fluids
			DIN EN, body, 1.4408, DN 32-100, PN 40, all fluids

¹⁾ Gases according to Article 4(1)(c.i), second indent
Liquids according to Article 4(1)(c.ii)

That the products mentioned above comply with the requirements of the following standards:

Directive of the European Parliament and of the Council on the harmonization of the laws of the Member States relating to the making available on the market of pressure equipment	2014/68/EU	of 15. May 2014
Applied conformity assessment procedure for fluids according to Article 4(1)	Module H	by Bureau Veritas 0062

The manufacturer's quality management system is monitored by the following notified body:
Bureau Veritas Services SAS, 4 place des Saisons, 92400 Courbevoie, France
Technical standards applied: DIN EN 12516-2, DIN EN 12516-3, ASME B16.34

Manufacturer: SAMSON AG, Weismuellerstrasse 3, 60314 Frankfurt am Main, Germany

Frankfurt am Main, 05. June 2024

p.p.c. Norbert Tollas

p.p.a. Norbert Tollas
Senior Vice President
Global Operations

i. V. P. Scheermesser

i. V. Peter Scheermesser
Director
Product Maintenance & Engineered Products

Revision 01

Classification: Public · SAMSON AKTIENGESELLSCHAFT · Weismuellerstrasse 3 · 60314 Frankfurt am Main, Germany

Page 3 of 3

EB 1015 EN



SAMSON AKTIENGESELLSCHAFT
Weismüllerstraße 3 · 60314 Frankfurt am Main, Germany
Phone: +49 69 4009-0 · Fax: +49 69 4009-1507
samson@samsongroup.com · www.samsongroup.com